



VEM  MOTOR

Schleifringläufermotoren

Inhaltsverzeichnis

Produktbeschreibung	6/2
Kurzübersicht der technischen Daten	6/4
Motorauswahldaten	
Baureihe S..R/SPR	
Regelschleifringläufer, Dauerbetrieb, S1	6/5
Baureihe S..H/SPH	
in Kran- und Hüttenwerksausführung,	
Betriebsart S3, S4/S5	6/7
Lagerung	6/26
Anschlusskästen	6/31
Maße	6/34

Produktbeschreibung

Noch immer werden Schleifringmotoren in vielen Industriebranchen eingesetzt. Mit ihren Eigenschaften bestimmen sie maßgeblich die Effektivität vieler Prozesse. Bei VEM-Drehstrommotoren mit Schleifringläufer verbinden sich die Vorteile dieser Antriebslösung mit dem außergewöhnlichen Know-how von VEM in ihrer Herstellung. Sie können

- aufgrund ihrer großen Modifikationsbreite auf Kundenapplikationen genau abgestimmt werden
- basieren auf einer einzigartigen technologischen Kompetenz und Erfahrung
- bewähren sich seit Jahrzehnten weltweit im Einsatz
- sind besonders geeignet für instabile Netze
- stehen in zwei Ausführungen zur Verfügung, deren Abmessungen und Baugrößen beide auf der IEC 72 basieren
- entsprechen im Allgemeinen Funkschutzgrad N nach DIN VDE 0875/DIN EN 55014.

Die Reihen SPER/S11R/SPEH/S11H sind als klassische IEC/DIN-Baureihen konzipiert, d. h. Anbaumessungen und Leistungszuordnung nach DIN 42679/DIN 42681, während die Reihen SPR/SPH/S10R/S10H von einer gegenüber

diesen DIN-Normen progressiven Leistungszuordnung ausgehen. Bei gleicher Baugröße bieten sie bis zu zwei Stufen höhere Leistung. Die Motoren sind ausgerüstet mit Radiallüftern aus Kunststoff oder einer Aluminiumgusslegierung, die unabhängig von der Drehrichtung des Motors kühlen (IC 411 nach IEC/EN 60034-6). Die maximal zulässige Betriebsdrehzahl ist in den Motorauswahldaten für Hebezeugmotoren angegeben. Nach IEC/EN 60034-1 werden die Motoren für 2 min einer Schleuderprüfung mit der 1,2-fachen maximalen Drehzahl unterworfen. Die Motoren können in Sonderausführung auch für höhere maximale Drehzahlen geliefert werden.

Auf Wunsch sind folgende Motorschutzvarianten möglich:

- Motorschutz mit Kaltleitertemperaturfühler in der Ständerwicklung
- Bimetall-Temperaturfühler als Öffner oder Schließer in der Ständerwicklung
- Widerstandsthermometer zur Wicklungs- oder Lagertemperaturüberwachung
- Stillstandsheizung zu Verhinderung von Kondenswasserbildung im Motorinneren.

Wirkprinzip und konstruktiver Aufbau

Das Wirkprinzip und der konstruktive Aufbau des Schleifringläufermotors ähneln dem Käfigläufermotor. Der Läufer erhält jedoch keine kurzgeschlossene Käfigwicklung, sondern eine dreiphasige Drehstromwicklung, deren Anschlüsse an das Schleifkontaktsystem geführt werden. Damit ergibt sich die Möglichkeit des Eingriffs in den Läuferkreis (meist über Vorwiderstände) und somit der Beeinflussung des Anlauf- und Bremsverhaltens.

Die Vorteile dabei sind:

- Mit Anlasswiderständen kann das Anzugsmoment beliebig bis zum Kippmoment variiert werden. Dabei treten geringe Anzugsströme (etwa das 2- bis 3-fache des Nennstromes) auf.

- Während des stationären Betriebes kann die Drehzahl (z. B. durch Einschalten von Vorwiderständen) in bestimmten Grenzen gesteuert werden.

Aus diesen Vorteilen ergibt sich das Anwendungsgebiet.

Er wird schwerpunktmäßig bei

- schwachen Netzen
 - Schweranlauf
 - Sanftanlauf
 - für Drehzahlsteuerung mit geringem Aufwand und kleinen Ansprüchen an die Steuergenauigkeit
- als robuste Alternative zum Frequenzumrichter eingesetzt. Das Hauptanwendungsgebiet ist noch heute der Einsatz in Hafenkrananlagen und Brecheranlagen.

Mechanischer Aufbau

Achshöhe	Baureihe	Werkstoff für			Fußbefestigung
		Gehäuse	Lagerschilde	Füße	
132–250 M, MX4	SPER/SPEH		GG		angeschraubt
250 MX6, 8	S11R/S11H				angegossen
280, 315	S11R/S11H				angegossen
132–225	SPR/SPH				angeschraubt
250, 280	S10R/S10H				angegossen

In den Bildern 1 und 2 sind die Hauptbauteile der VEM-Schleifringläufermotoren zu sehen. Für die Gehäusebauteile,

Ständerausführung, Lagerung, Belüftung und Farbgebung gelten die Ausführungen der VEM-Standard-Käfigläufermotoren.

Läufer

Im Gegensatz zum Käfigläufer ist die Läuferwicklung als Drehstromwicklung ausgeführt. Die Anschlüsse sind an

das Schleifkontaktsystem geführt. Der Läufer trägt einen Schleifringkörper mit drei Schleifringen.

Wicklung und Isolation

Die Läuferwicklung des Schleifringläufers ist bezüglich der Isolationsausführung wie Hauptisolation, Phasenisolation, Keile und Zwischenkappen, Wickeldraht und Imprägnierung

wie die Ständerwicklung der Käfigläufermotoren ausgeführt. Die Wickelköpfe werden zusätzlich über Schrupfbandagen gesichert.

Schleifkontaktsystem

Schleifringkörper und Bürstensystem sind typenabhängig entweder im Schleifringraum des Gehäuses auf der Motor-D-Seite (Baugröße 132 bis 315 M) oder im N-Lagerschild (ab Baugröße 315MX) angeordnet. Als Bürstenhalter

werden doppelte Taschenbürstenhalter eingesetzt. Für das Schleifkontaktsystem wird üblicherweise die Materialpaarung Bronze-Metallgraphit eingesetzt.



Bild 1: Konstruktiver Aufbau der Schleifringläufer S..R/S..H 132 bis 315 M

- | | | |
|----------------------|-----------------|-------------------------|
| 1 Gehäuse | 5 Läufer | 9 Lüfterhaube |
| 2 Lagerschild | 6 Lagerung | 10 Schleifkontaktsystem |
| 3 Flanschlagerschild | 7 Klemmenkasten | 11 Bediendeckel |
| 4 Fuß | 8 Lüfter | |

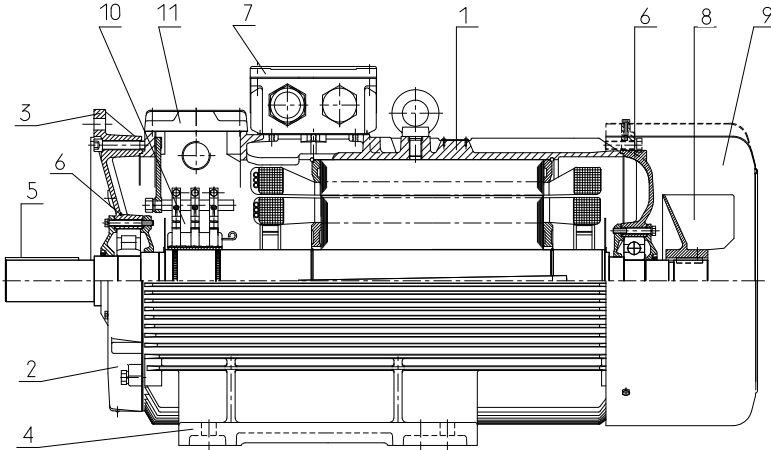

Bild 2: Konstruktiver Aufbau der Schleifringläufer S11R/S11H 315 MX-LY

- | | |
|-------------------------|---|
| 10 Schleifkontaktsystem | 12 Nachschmiereinrichtung |
| 11 Bediendeckel | 13 Anschlusskasten für Schleifkontaktsystem |

Kurzübersicht der technischen Daten

Die wichtigsten technischen Daten sind in der nachfolgenden Tabelle zusammengefasst. Weitere Informationen entnehmen Sie dem Katalogteil Einführung (Kapitel 1).

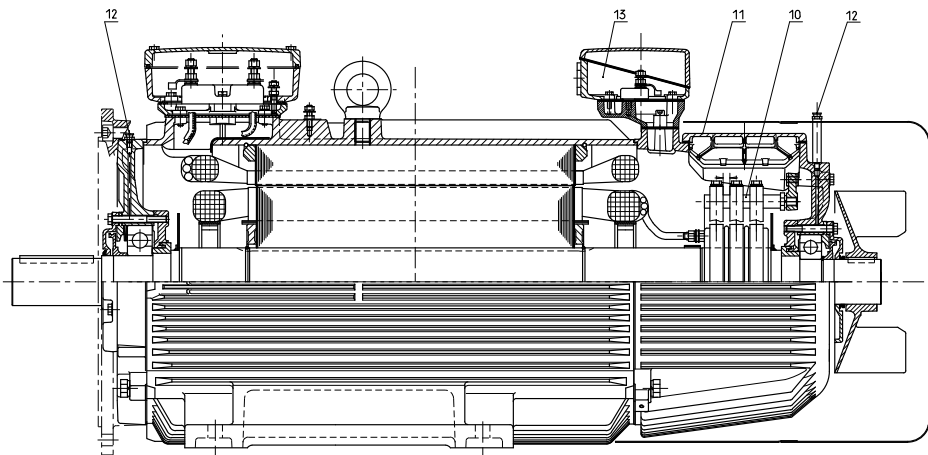
Produktgruppe	Schleifringläufer, IEC/DIN
Bemessungsleistung	2,2 kW bis 315 kW 4- bis 10-polig
Baugrößen	132 bis 315
Gehäusematerial	Grauguss mit angegossenen Motorfüßen
Bemessungsdrehmoment	25 Nm bis 2030 Nm
Wirkungsgradkennzeichnung/ Wirkungsgradbestimmung	ohne / IEC/EN 60034-2
Schaltungsarten	Motoren mit einer Drehzahl sind standardmäßig in D/Y-Schaltung ausgeführt.
Isolation der Ständerwicklung	Thermische Klasse 155, optional 155 [F(B)] nach IEC/EN 60034-1
Schutzart	IP 55 nach IEC/EN 60034-5
Kühlart	nach IEC/EN 60034-6 eigenbelüftet, IC 411 (Baureihe W4.R)
Kühlmitteltemperatur/Aufstellungshöhe	standardmäßig -20 °C bis +40 °C, Aufstellungshöhe 1000 m über NN
Bemessungsspannung	Normspannungen nach EN 60038 50 Hz: 230 V, 400 V, 500 V, 690 V 60 Hz: 275 V, 460 V, 480 V, 600 V Spannungsbereiche A und B nach IEC/EN 60034-1
Betriebsarten	S1, Dauerbetrieb, Betriebsart S3, 25/40/60 %/100 % ED Betriebsart S4/S5, 150 c/h, 300/600 c/h
Bauformen	IM B3, IM B35, IM B5 und abgeleitete Bauformen nach IEC/EN 60034-7
Anstrich	Normalanstrich „moderate“, Farbton RAL 7031, blaugrau Sonderanstrich „worldwide“, Farbton RAL 7031, blaugrau
Schwinggrößenstufe	standardmäßig Stufe „A“ ist für Maschinen ohne besondere Schwingungsanforderungen
Wellenenden	nach DIN 748 (IEC 60072), Auswuchtart „Halbkeilwuchtung“
Transponder	optional RFID-System iID®2000 (13,56 MHz basierend auf ISO 15693)
Grenzdrehzahlen	Die Angaben entnehmen Sie dem Abschnitt Grenzdrehzahlen im Katalogteil Motoren für Umrichterbetrieb, Kapitel 4.
Lagerausführung	Die Angaben entnehmen Sie den Tabellen zur Lagerung.
Motormassen	Die Angaben entnehmen Sie den technischen Auswahllisten.
Anschlusskästen	Die Angaben entnehmen Sie dem Abschnitt Anschlusskästen.
Toleranzen	Die Angaben entnehmen Sie dem Abschnitt Toleranzen der Technischen Erläuterungen, Kapitel 1.
Optionen	Die Angaben entnehmen Sie dem Abschnitt Toleranzen im Katalogteil Einführung, Kapitel 1.
Dokumentation	Die Angaben entnehmen Sie dem Abschnitt Modifikationsübersicht im Katalogteil Einführung, Kapitel 1.

Motorauswahldaten

Drehstrommotoren mit Schleifringläufer

Reihen SPER und S11R, Betriebsart S1, Dauerbetrieb
mit Oberflächenkühlung, Kühlart IC 411
Wärmeklasse F, Schutzart IP 54/IP 55

Motorauswahldaten										Bemessungspunkt 400 V, 50 Hz		
Typ	P	n	η	$\cos\varphi$	I	Läufer			M_k/M_B	J	m	
	kW	min ⁻¹	%	A	400 V	R	U	I	-	kgm ²	kg	
				-	A	Ω	A	A				
Synchrondrehzahl 1500 min⁻¹ – 4-polige Ausführung												
SPER 132 M4	4	1435	83,0	0,83	8,4	0,1004	130	Y	19	2,8	0,043	85
SPER 132 MX4	5,5	1450	83,0	0,82	11,5	0,1081	170	Y	20	3,4	0,050	95
SPER 160 M4	7,5	1460	86,0	0,83	15,2	0,0922	180	Y	26	3,1	0,093	133
SPER 160 L4	11	1465	87,0	0,83	22,0	0,0979	260	Y	26	4	0,128	150
SPER 180 L4	15	1465	87,5	0,86	29,0	0,0675	250	Y	37	3,6	0,195	204
SPER 200 L4	18,5	1470	89,0	0,86	35,0	0,0346	220	Y	52	3,8	0,330	280
SPER 200 LX4	22	1470	90,0	0,86	41,0	0,0354	255	Y	53	4	0,403	305
SPER 225 M4	30	1475	91,0	0,87	54,5	0,0329	300	Y	62	4,5	0,476	330
SPER 250 M4	37	1475	92,0	0,86	67,5	0,0231	175	Δ	131	4,2	0,568	435
SPER 250 MX4	45	1480	92,2	0,89	79,0	0,0283	210	Δ	132	4,2	0,632	450
S11R 280 S4	55	1480	92,2	0,88	98,0	0,0090	230	Y	148	4	1,250	590
S11R 280 M4	75	1485	92,5	0,86	136	0,0202	290	Δ	160	5	1,850	710
S11R 315 S4	90	1488	93,2	0,88	158	0,0166	280	Δ	199	5,5	2,850	890
S11R 315 M4	110	1488	94,0	0,90	188	0,0171	345	Δ	197	5,2	3,480	1010
S11R 315 MX4	132	1488	94,8	0,90	223	0,0180	410	Δ	199	5,3	5,320	1275
S11R 315 MY4	160	1488	94,9	0,90	270	0,0073	505	Y	196	5,3	5,960	1350
S11R 315 LX4	200	1490	95,5	0,91	332	0,0264	640	Δ	193	5,3	7,290	1540
S11R 315 LY4	250	1490	95,7	0,90	419	0,0273	725	Δ	213	4,5	8,060	1620
Synchrondrehzahl 1000 min⁻¹ – 6-polige Ausführung												
SPER 132 M6	3	955	79,0	0,77	7,1	0,1180	110	Y	17	2,8	0,050	85
SPER 132 MX6	4	960	80,0	0,76	9,5	0,1249	130	Y	19	3,1	0,063	95
SPER 160 M6	5,5	965	84,0	0,84	11,5	0,1246	170	Y	20	2,4	0,135	133
SPER 160 L6	7,5	965	84,5	0,82	15,5	0,1927	250	Y	19	2,6	0,162	145
SPER 180 L6	11	965	85,0	0,83	22,5	0,0790	205	Y	33	3	0,279	204
SPER 200 L6	15	970	87,0	0,84	29,5	0,0591	230	Y	40	3,2	0,371	280
SPER 225 M6	18,5	975	88,5	0,85	35,5	0,0413	225	Y	51	3,4	0,464	305
SPER 225 MX6	22	980	90,0	0,83	42,5	0,0437	260	Y	52	3,2	0,535	320
SPER 250 M6	30	980	90,5	0,88	54,5	0,0222	125	Δ	148	3,3	1,000	425
S11R 250 MX6	37	985	91,5	0,88	66,5	0,0243	165	Δ	139	3,1	1,610	580
S11R 280 S6	45	985	92,0	0,88	80,0	0,0237	175	Δ	159	3,3	1,820	620
S11R 280 M6	55	985	92,0	0,86	100	0,0220	205	Δ	166	3,9	2,370	710
S11R 315 S6	75	990	94,0	0,88	130	0,0163	235	Δ	197	4	3,900	950
S11R 315 M6	90	990	93,5	0,87	159	0,0173	280	Δ	199	3,2	4,310	1000
S11R 315 MX6	110	987	94,5	0,88	191	0,0070	345	Y	197	3,5	6,800	1290
S11R 315 MY6	132	989	94,8	0,88	224	0,0100	445	Y	183	3,6	8,000	1380
S11R 315 LX6	160	990	95,2	0,89	273	0,0101	515	Y	192	3,5	9,600	1590
Synchrondrehzahl 750 min⁻¹ – 8-polige Ausführung												
SPER 132 M8	2,2	690	75,0	0,73	5,8	0,1968	100	Y	13,5	2,1	0,048	85
SPER 132 MX8	3,0	705	78,0	0,73	7,6	0,1680	120	Y	15,5	2,2	0,058	95
SPER 160 M8	4,0	720	82,0	0,72	9,8	0,1444	150	Y	16,5	2	0,135	134
SPER 160 L8	5,5	720	82,0	0,72	13,5	0,1472	180	Y	19	2,2	0,163	145
SPER 180 L8	7,5	725	84,0	0,74	17,5	0,1013	185	Y	25	3	0,240	204
SPER 200 L8	11,0	725	86,5	0,78	23,5	0,0831	210	Y	30	2,2	0,362	280
SPER 225 M8	15,0	725	88,0	0,78	31,5	0,0421	190	Y	49	2,8	0,452	305
SPER 225 MX8	18,5	730	88,0	0,79	38,5	0,0484	235	Y	49	2,6	0,568	330
SPER 250 M8	22	732	90,0	0,81	43,5	0,0136	135	Y	101	2,8	0,990	425
S11R 250 MX8	30	735	91,0	0,83	57,5	0,0095	160	Y	116	2,4	1,780	600
S11R 280 S8	37	737	91,0	0,81	72,5	0,0102	180	Y	127	2,8	1,950	660
S11R 280 M8	45	737	92,0	0,78	90,5	0,0112	220	Y	126	2,5	2,370	710
S11R 315 S8	55	740	92,5	0,82	104	0,0096	240	Y	142	2,5	3,950	950
S11R 315 M8	75	738	92,5	0,83	141	0,0399	295	Δ	157	2,3	4,310	1000
S11R 315 MX8	90	742	93,9	0,75	184	0,0066	280	Y	198	3,4	6,800	1290
S11R 315 MY8	110	742	94,1	0,79	214	0,0090	380	Y	179	3,0	8,100	1390
S11R 315 LX8	132	742	94,4	0,80	252	0,0100	440	Y	186	2,7	9,800	1600

Drehstrommotoren mit Schleifringläufer

Reihen SPR und S10R, progressive Leistungszuordnung
 mit Oberflächenkühlung, Betriebsart S1, Dauerbetrieb
 Wärmeklasse F, Schutzart IP 54, 50 Hz

Motorauswahldaten											Bemessungspunkt 400 V, 50 Hz		
Typ	P kW	n min ⁻¹	η %	cosφ A -	I 400 V A	R Ω	Läufer			M _k /M _B -	J kgm ²	m kg	
							U A	I A					
Synchrondrehzahl 1500 min⁻¹ – 4-polige Ausführung													
SPR 132 M4	4,0	1435	83,0	0,83	8,4	0,1670	160	Y	15,5	2,8	0,043	85	
SPR 132 MX4	5,5	1450	83,0	0,82	11,5	0,1380	180	Y	19,0	3,4	0,050	95	
SPR 132 L4	7,5	1450	84,0	0,82	15,5	0,1080	200	Y	23,0	3,1	0,060	105	
SPR 160 M4	11,0	1465	87,0	0,83	22,0	0,0902	250	Y	27,0	4,0	0,128	150	
SPR 160 L4	15,0	1470	87,5	0,82	30,0	0,0702	280	Y	33,0	4,2	0,145	165	
SPR 180 M4	18,5	1470	89,5	0,87	34,5	0,0275	200	Y	57,0	4,3	0,250	225	
SPR 180 L4	22,0	1470	90,5	0,89	39,5	0,0426	270	Y	50,0	4,3	0,285	255	
SPR 200 M4	30,0	1475	91,0	0,87	54,5	0,0156	210	Y	88,0	4,5	0,476	330	
SPR 200 L4	37,0	1480	91,5	0,87	67,0	0,0180	270	Y	85,0	5,0	0,590	375	
SPR 225 M4	45,0	1480	92,2	0,89	79,0	0,0162	280	Y	100,0	4,2	0,632	450	
S10R 250 M4	55,0	1480	92,2	0,88	98,0	0,0168	330	Y	103,0	4,0	1,030	590	
S10R 250 L4	75,0	1485	92,5	0,86	136,0	0,0163	450	Y	103,0	5,0	1,850	710	
S10R 280 M4	90,0	1488	93,2	0,88	158,0	0,0305	400	Δ	139,0	5,5	2,850	890	
S10R 280 L4	110	1488	93,7	0,88	193,0	0,0321	490	Δ	139,0	5,2	3,480	1010	
Synchrondrehzahl 1000 min⁻¹ – 6-polige Ausführung													
SPR 132 M6	3,0	955	79,0	0,77	7,1	0,1250	120	Y	16,0	2,8	0,050	85	
SPR 132 MX6	4,0	960	80,0	0,76	9,5	0,1410	150	Y	17,0	3,1	0,063	95	
SPR 132 L6	5,5	960	82,0	0,79	12,5	0,1660	180	Y	19,0	2,8	0,078	105	
SPR 160 M6	7,5	965	84,5	0,82	15,5	0,0704	165	Y	28,0	2,6	0,162	145	
SPR 160 L6	11,0	975	85,0	0,80	23,5	0,0526	190	Y	35,0	3,0	0,203	165	
SPR 180 M6	15,0	970	88,0	0,85	29,0	0,0563	220	Y	42,0	3,2	0,315	225	
SPR 180 L6	18,5	975	88,5	0,85	35,5	0,0606	270	Y	42,0	3,5	0,358	255	
SPR 200 M6	22,0	980	90,0	0,83	42,5	0,0165	160	Y	85,0	3,2	0,535	320	
SPR 225 M6	30,0	980	90,5	0,88	54,5	0,0223	230	Y	81,0	3,3	1,000	425	
S10R 250 M6	37,0	985	91,5	0,88	66,5	0,0243	270	Y	85,0	3,1	1,610	580	
S10R 250 MX6	45,0	985	92,0	0,88	80,0	0,0179	280	Y	99,0	3,3	1,820	620	
S10R 280 M6	55,0	987	93,0	0,88	97,0	0,0438	300	Δ	114,0	3,0	3,350	850	
S10R 280 L6	75,0	990	93,5	0,88	132,0	0,0455	400	Δ	116,0	3,6	3,900	950	
Synchrondrehzahl 750 min⁻¹ – 8-polige Ausführung													
SPR 132 M8	2,2	690	75,0	0,73	5,8	0,1980	100	Y	14,0	2,1	0,048	85	
SPR 132 MX8	3,0	705	78,0	0,73	7,6	0,1680	120	Y	16,0	2,2	0,058	95	
SPR 132 L8	4,0	710	79,0	0,73	10,0	0,1960	150	Y	17,0	2,2	0,068	105	
SPR 160 M8	5,5	720	82,0	0,72	13,5	0,0679	125	Y	28,0	2,2	0,163	145	
SPR 160 L8	7,5	725	84,0	0,74	17,5	0,0526	135	Y	35,0	2,6	0,190	170	
SPR 180 M8	11,0	725	86,0	0,76	24,5	0,0428	150	Y	45,0	2,8	0,308	225	
SPR 180 L8	15,0	730	87,0	0,77	32,5	0,0398	180	Y	51,0	2,9	0,365	260	
SPR 200 M8	18,5	730	88,0	0,79	38,5	0,0164	140	Y	82,0	2,6	0,568	330	
SPR 225 M8	22,0	732	90,0	0,81	43,5	0,0205	180	Y	79,0	2,8	0,990	425	
S10R 250 M8	30,0	735	91,0	0,83	57,5	0,0195	220	Y	84,0	2,4	1,780	600	
S10R 250 L8	37,0	737	91,0	0,81	72,5	0,0209	270	Y	85,0	2,8	1,950	660	
S10R 280 M8	45,0	738	92,0	0,83	85,0	0,0111	220	Y	126,0	2,2	3,300	850	
S10R 280 L8	55,0	740	92,5	0,82	104,7	0,0164	310	Y	110,0	2,5	3,950	950	

Drehstrommotoren mit Schleifringläufer für Aussetzbetrieb

Reihen SPEH und S11H
mit Oberflächenkühlung, Betriebsart S3,
Wärmeklasse F, Schutzart IP 54/IP 55

Motorauswahldaten											Bemessungspunkt 400 V, 50 Hz				
Typ	S3-	P	n	cos φ	η	I	R	Läufer	I	M _k /M _B	n _{max}	J	m		
	%	kW	min ⁻¹	%	%	400 V A	Ω	U V	A	-	min ⁻¹	kgm ²	kg		
Synchrondrehzahl 1500 min ⁻¹ – 4-polige Ausführung															
SPEH 132 M4	100	4,8	1450	0,69	80,0	12,5				3,4					
	60	5,3	1440	0,72	80,5	13,0			18,5	3,1					
	40	6,3	1430	0,76	80,5	15,0	0,1141	160	Y	24,5	2,6	2500	0,043	85	
	25	7,0	1420	0,79	80,0	16,0				27,0	2,3				
	15	8,0	1410	0,77	80,0	18,7				31,0	2,0				
SPEH 132 MX4	100	5,5	1450	0,76	83,0	12,5				3,7					
	60	6,6	1440	0,79	83,0	14,5				19,0	3,1				
	40	7,5	1435	0,81	83,0	16,2	0,1168	180	Y	25,5	2,7	2500	0,050	95	
	25	8,7	1425	0,82	82,0	18,7				30,0	2,3				
	15	9,5	1415	0,82	81,0	20,5				32,5	2,1				
SPEH 160 M4	100	7,5	1460	0,80	85,0	16,0				4,0					
	60	8,5	1455	0,83	85,0	17,5				29,0	3,5				
	40	10,0	1445	0,86	85,0	19,5	0,0792	180	Y	34,5	3,0	2400	0,093	133	
	25	11,0	1440	0,87	84,5	21,5				38,0	2,7				
	15	13,0	1430	0,88	84,0	25,5				44,5	2,3				
SPEH 160 L4	100	11,0	1465	0,75	85,0	25,0				4,6					
	60	12,5	1460	0,78	85,5	27,0				30,0	4,0				
	40	14,5	1455	0,82	85,5	30,0	0,0919	260	Y	34,5	3,5	2400	0,128	150	
	25	16,5	1450	0,85	85,5	33,0				39,0	3,0				
	15	19,5	1445	0,86	85,0	38,5				46,5	2,6				
SPEH 180 L4	100	15,0	1470	0,72	85,0	35,5				5,7					
	60	17,0	1465	0,75	85,0	38,5				39,0	5,0				
	40	19,5	1460	0,79	85,5	41,5	0,0639	270	Y	44,5	4,4	2200	0,195	204	
	25	22,0	1455	0,82	86,0	45,0				57,0	3,9				
	15	27,0	1450	0,82	86,0	55,0				62,0	3,2				
SPEH 200 L4	100	18,5	1470	0,82	88,5	37,0				4,4					
	60	21,0	1465	0,84	89,0	40,5				49,5	4,4				
	40	24,0	1460	0,86	89,0	45,5	0,0344	230	Y	57,0	3,9	2200	0,330	280	
	25	28,0	1455	0,87	88,5	52,5				75,0	2,9				
	15	33,0	1450	0,87	88,0	62,0				89,0	2,5				
SPEH 200 LX4	100	22,0	1475	0,87	90,0	40,5				4,2					
	60	25,0	1470	0,88	90,0	45,5				49,5	4,2				
	40	28,0	1465	0,89	90,0	50,5	0,0377	275	Y	56,0	3,7	2200	0,403	305	
	25	33,0	1460	0,90	90,0	59,0				63,0	3,3				
	15	40,0	1455	0,89	89,0	73,0				74,0	2,8				
SPEH 225 M4	100	30	1475	0,83	90,0	58,0				4,9					
	60	34	1470	0,85	90,0	64,0				56,0	3,7				
	40	39	1465	0,87	90,0	72,0	0,0367	330	Y	63,0	3,3	2200	0,476	330	
	25	45	1460	0,88	90,0	82,0				74,0	2,8				
	15	53	1455	0,89	89,0	96,5				99,0	2,3				
SPEH 250 M4	100	37	1482	0,84	92,0	69,0				4,5					
	60	42	1478	0,85	92,0	77,5				49,5	4,2				
	40	48	1475	0,86	92,0	87,5	0,0083	195	Y	56,0	3,7	2200	0,568	425	
	25	55	1472	0,88	91,5	99,0				63,0	3,3				
	15	65	1467	0,88	91,0	117				74,0	2,8				

Drehstrommotoren mit Schleifringläufer für Aussetzbetrieb

Reihen SPEH und S11H
mit Oberflächenkühlung, Betriebsart S3,
Wärmeklasse F, Schutzart IP 54/IP 55

Motorauswahldaten											Bemessungspunkt 400 V, 50 Hz				
Typ	S3-	P	n	cos φ	η	I	R	Läufer	I	M _k /M _B	n _{max}	J	m		
	%	kW	min ⁻¹	%	%	400 V A	Ω	U V	A	-	min ⁻¹	kgm ²	kg		
Synchrondrehzahl 1500 min ⁻¹ – 4-polige Ausführung															
SPEH	250 MX4	100	45	1480	0,86	91,8	82,5			118	4,2				
		60	51	1477	0,88	91,8	91,5			134	3,7				
		40	58	1475	0,89	91,8	103	0,0105	235	Y	152	3,3	2200	0,632	450
		25	67	1470	0,90	91,5	117				176	2,8			
		15	80	1465	0,92	91,1	138				210	2,4			
S11H	280 S4	100	60	1480	0,84	92,0	112			154	4,0				
		60	68	1475	0,86	92,0	124			175	3,5				
		40	75	1475	0,87	92,0	135	0,0086	240	Y	193	3,2	2200	1,25	590
		25	90	1470	0,89	92,0	159				232	2,7			
		15	105	1465	0,89	91,5	186				270	2,3			
S11H	280 M4	100	75	1486	0,81	92,3	145			149	5,7				
		60	85	1484	0,83	92,6	160			169	5,0				
		40	95	1483	0,85	92,8	174	0,0239	310	Δ	189	4,6	2200	1,85	710
		25	110	1480	0,86	92,8	199				219	3,9			
		15	132	1478	0,88	92,8	233				263	3,2			
S11H	315 S4	100	90	1488	0,88	93,5	158			179	5,8				
		60	100	1487	0,89	93,5	173			199	5,3				
		40	115	1485	0,91	93,7	195	0,0177	310	Δ	229	4,6	2200	2,85	890
		25	132	1483	0,92	93,7	221				263	4,0			
		15	160	1479	0,92	93,5	268				319	3,3			
S11H	315 M4	100	110	1485	0,91	94,2	185			181	5,4				
		60	125	1483	0,92	94,3	208			206	4,8				
		40	140	1482	0,93	94,3	230	0,0210	375	Δ	231	4,3	2200	3,48	1010
		25	160	1480	0,93	94,2	264				264	3,7			
		15	190	1475	0,94	94,1	310				313	3,1			
S11H	315 MX4	100	132	1488	0,90	94,8	223			199	5,3				
		60	150	1486	0,90	94,9	253			226	4,6				
		40	165	1484	0,91	94,8	276	0,0180	410	Δ	249	4,2	2200	5,32	1275
		25	190	1482	0,92	94,7	315				286	3,6			
		15	225	1479	0,92	94,6	373				339	3,1			
S11H	315 MY4	100	160	1488	0,90	94,9	270			196	5,3				
		60	180	1486	0,90	94,9	304			220	4,7				
		40	200	1485	0,91	94,9	334	0,0073	505	Y	245	4,2	2200	5,96	1350
		25	230	1483	0,92	94,9	380				281	3,7			
		15	270	1481	0,94	94,9	437				330	3,1			
S11H	315 LX4	100	200	1490	0,91	95,5	332			193	5,3				
		60	225	1489	0,92	95,5	370			217	4,7				
		40	250	1487	0,92	95,5	411	0,0264	640	Δ	241	4,2	2200	7,29	1540
		25	290	1486	0,92	95,3	477				280	3,6			
		15	340	1484	0,92	95,2	560				328	3,1			
S11H	315 LY4	100	250	1488	0,90	95,7	419			213	4,5				
		60	280	1485	0,91	95,6	465			234	4,0				
		40	315	1482	0,91	95,5	523	0,0273	725	Δ	260	3,6	2200	8,06	1620
		25	360	1479	0,90	95,3	606				302	3,1			
		15	430	1472	0,90	94,7	728				362	2,6			

Drehstrommotoren mit Schleifringläufer für Aussetzbetrieb

Reihen SPEH und S11H
mit Oberflächenkühlung, Betriebsart S3,
Wärmeklasse F, Schutzart IP 54/IP 55

Motorauswahldaten											Bemessungspunkt 400 V, 50 Hz			
Typ	S3-	P	n	cos φ	η	I	R	Läufer	I	M _k /M _B	η _{max}	J	m	
	%	kW	min ⁻¹	%	%	400 V A	Ω	U V	A	-	min ⁻¹	kgm ²	kg	
Synchrondrehzahl 1000 min ⁻¹ – 6-polige Ausführung														
SPEH 132 M6	100	3,5	945	0,71	74,0	9,6				18	3,1			
	60	3,9	940	0,74	74,5	10,5				20	2,7			
	40	4,5	930	0,77	74,0	11,5	0,1180	120	Y	23	2,4	2500	0,050	
	25	5	920	0,80	74,0	12,5				26	2,1			
	15	6	915	0,80	73,5	14,7				31	1,8			
SPEH 132 MX6	100	4	965	0,74	79,0	9,9				17,5	3,7			
	60	4,8	955	0,77	79,0	11,4				21	3,1			
	40	5,5	950	0,80	79,0	12,5	0,1151	140	Y	24,5	2,7	2500	0,063	
	25	6,5	940	0,82	79,0	14,5				28,5	2,3			
	15	7	925	0,83	78,0	15,5				31	2,1			
SPEH 160 M6	100	5,5	973	0,67	81,0	14,5				19	4,2			
	60	6	970	0,70	81,5	15,0				20,5	3,8			
	40	7	965	0,74	82,0	16,5	0,1097	180	Y	24	3,3	2400	0,135	
	25	8	960	0,78	82,0	18,0				27,5	2,9			
	15	9,5	955	0,80	82,0	21,0				32,5	2,4			
SPEH 160 L6	100	7,5	972	0,73	82,0	18,0				18	3,8			
	60	8,5	970	0,76	83,0	19,5				20	3,4			
	40	10	965	0,80	83,0	21,5	0,1600	260	Y	24	2,9	2400	0,162	
	25	11,5	960	0,82	83,0	24,5				27,5	2,5			
	15	13,5	950	0,84	82,0	28,5				32	2,1			
SPEH 180 L6	100	11	968	0,78	84,0	24,5				29,5	3,8			
	60	12,5	962	0,81	84,0	26,5				33,5	3,3			
	40	14,5	957	0,84	84,0	29,5	0,0959	230	Y	39	2,9	2200	0,279	
	25	16,5	950	0,85	83,5	33,5				44,5	2,5			
	15	21	940	0,85	83,0	43,0				57	2,0			
SPEH 200 L6	100	15	973	0,79	86,5	31,5				36,5	3,6			
	60	17,5	968	0,82	86,5	35,5				42,5	3,1			
	40	20	963	0,84	86,0	40,0	0,0754	255	Y	48,5	2,7	2080	0,371	
	25	23	957	0,85	85,5	45,5				56	2,3			
	15	28	950	0,86	85,0	55,5				68	1,9			
SPEH 225 M6	100	18,5	978	0,77	87,5	39,5				46	4,3			
	60	22	973	0,81	87,5	45,0				55	3,6			
	40	25	970	0,83	87,5	49,5	0,0499	250	Y	62	3,2	2080	0,464	
	25	28	965	0,84	87,0	55,5				69	2,8			
	15	35	960	0,85	87,0	68,5				87	2,2			
SPEH 225 MX6	100	22	980	0,82	88,0	39,0				47	3,9			
	60	26	975	0,84	88,0	44,0				56	3,3			
	40	30	970	0,85	88,0	58,0	0,0561	290	Y	64	2,9	2080	0,535	
	25	34	965	0,87	88,0	65,5				73	2,5			
	15	42	960	0,88	87,0	79,0				90	2,0			
SPEH 250 M6	100	27	980	0,83	89,0	52,5				119	4,2			
	60	32	980	0,84	89,0	61,5				141	3,6			
	40	37	980	0,85	89,0	70,5	0,0103	140	Y	163	3,1	2080	1,00	
	25	42	975	0,86	89,0	79,0				185	2,7			
	15	55	965	0,87	89,0	103				243	2,1			

Drehstrommotoren mit Schleifringläufer für Aussetzbetrieb

Reihen SPEH und S11H
mit Oberflächenkühlung, Betriebsart S3,
Wärmeklasse F, Schutzart IP 54/IP 55

Motorauswahldaten											Bemessungspunkt 400 V, 50 Hz				
Typ	S3- %	P kW	n min ⁻¹	cos φ	η %	I 400 V A	R Ω	Läufer		I A	M _k /M _B -	n _{max} min ⁻¹	J kgm ²	m kg	
								U V							
Synchrondrehzahl 1000 min ⁻¹ – 6-polige Ausführung															
S11H 250 MX6	100	34	987	0,82	90,0	66,5				120	4,4				
	60	39	985	0,85	90,0	73,5			138	3,8					
	40	45	985	0,86	90,0	83,5	0,0261	175	Δ	159	3,3	2080	1,61	580	
	25	52	980	0,87	90,0	96,0				184	2,8				
	15	70	974	0,88	90,0	126,0				247	2,1				
S11H 280 S6	100	45	987	0,81	91,0	88,0				146	4,2				
	60	52	985	0,83	91,0	99,5			169	3,7					
	40	60	982	0,85	91,0	112	0,0248	190	Δ	195	3,2	2080	1,82	600	
	25	70	979	0,86	91,0	129				228	2,7				
	15	85	975	0,86	90,0	159				276	2,2				
S11H 280 M6	100	55	986	0,84	92,5	102				144	4,0				
	60	64	983	0,86	92,5	116			168	3,4					
	40	75	980	0,87	92,3	135	0,0273	235	Δ	197	2,9	2080	2,37	700	
	25	85	978	0,88	92,1	151				223	2,5				
	15	105	975	0,88	91,8	188				276	2,1				
S11H 315 S6	100	75	990	0,82	92,5	143				178	4,1				
	60	87	988	0,84	92,5	162			207	3,6					
	40	100	987	0,86	92,5	181	0,0175	260	Δ	238	3,1	2080	3,95	950	
	25	115	985	0,87	92,5	206				273	2,7				
	15	130	983	0,87	92,5	235				309	2,4				
S11H 315 M6	100	90	988	0,85	92,5	165				180	4,0				
	60	105	986	0,87	92,6	188			209	3,4					
	40	120	984	0,88	92,5	213	0,0241	310	Δ	239	3,0	2080	4,31	1000	
	25	140	981	0,88	92,2	249				279	2,5				
	15	165	978	0,88	91,5	296				329	2,1				
S11H 315 MX6	100	110	987	0,87	94,4	193				197	3,5				
	60	125	986	0,88	94,3	217			224	3,1					
	40	140	984	0,89	94,1	241	0,0070	345	Y	251	2,7	2080	6,8	1290	
	25	160	982	0,89	94,0	276				286	2,4				
	15	190	980	0,89	93,6	329				340	2,0				
S11H 315 MY6	100	132	989	0,88	94,8	228				183	3,6				
	60	150	987	0,88	94,6	260			208	3,1					
	40	170	986	0,88	94,4	295	0,0100	445	Y	236	2,8	2080	8,0	1380	
	25	195	984	0,87	94,0	344				271	2,4				
	15	230	981	0,86	93,0	415				319	2,0				
S11H 315 LX6	100	160	990	0,89	95,2	273				192	3,5				
	60	185	989	0,89	95,1	315			222	3,0					
	40	210	988	0,89	95,0	358	0,0101	515	Y	252	2,6	2080	9,6	1590	
	25	240	986	0,89	94,6	411				288	2,3				
	15	280	983	0,88	93,5	491				336	2,0				

Drehstrommotoren mit Schleifringläufer für Aussetzbetrieb

Reihen SPEH und S11H
mit Oberflächenkühlung, Betriebsart S3,
Wärmeklasse F, Schutzart IP 54/IP 55

Motorauswahldaten											Bemessungspunkt 400 V, 50 Hz				
Typ	S3-	P	n	cos φ	η	I	R	Läufer	I	M _k /M _B	η _{max}	J	m		
	%	kW	min ⁻¹	%	%	400 V A	Ω	U V	A	-	min ⁻¹	kgm ²	kg		
Synchrondrehzahl 750 min ⁻¹ – 8-polige Ausführung															
SPEH 132 M8	100	2,3	710	0,62	70,0	7,6			10,0	2,9					
	60	2,8	700	0,68	70,0	8,5			12,5	2,3					
	40	3,3	685	0,72	70,0	9,5	0,3030	145	Y	15,0	2,0	2500	0,048	85	
	25	3,3	685	0,72	70,0	9,5			15,0	2,0					
	15	3,3	685	0,72	70,0	9,5			15,0	2,0					
SPEH 132 MX8	100	3,0	710	0,62	74,0	9,4			11,5	3,0					
	60	3,6	700	0,67	74,0	10,5			14,0	2,5					
	40	4,3	690	0,72	74,0	12,0	0,2800	160	Y	16,5	2,0	2500	0,058	95	
	25	4,9	680	0,74	74,0	13,0			19,0	1,8					
	15	4,9	680	0,74	74,0	13,0			19,0	1,8					
SPEH 160 M8	100	3,6	725	0,59	79,0	11,0			12,0	3,0					
	60	4,5	720	0,65	80,0	12,5			16,5	2,4					
	40	5,3	714	0,70	80,0	13,5	0,1980	190	Y	17,5	2,1	2400	0,135	133	
	25	6,0	707	0,73	79,5	15,0			19,5	1,8					
	15	6,2	705	0,74	79,0	15,5			20,0	1,8					
SPEH 160 L8	100	5,5	730	0,58	79,0	17,3			17,0	3,3					
	60	6,0	725	0,64	79,0	17,1			18,5	3,0					
	40	7,2	720	0,69	79,0	19,0	0,1590	200	Y	21,5	2,6	2400	0,162	145	
	25	8,0	715	0,72	79,0	20,5			25,0	2,3					
	15	9,5	710						29,5	1,9					
SPEH 180 L8	100	7,5	725	0,66	82,0	20,0			22,0	3,7					
	60	8,5	720	0,70	82,5	21,5			25,0	3,3					
	40	10,0	715	0,74	82,5	23,5	0,1312	210	Y	29,5	2,8	2200	0,279	204	
	25	11,5	710	0,78	82,0	26,0			34,0	2,4					
	15	15,0	700	0,79	81,5	33,5			44	1,9					
SPEH 200 L8	100	11,0	728	0,68	84,0	28,0			27	3,5					
	60	12,5	725	0,71	84,0	30,5			31	3,1					
	40	14,5	720	0,74	84,0	33,5	0,0977	250	Y	36	2,7	1875	0,279	280	
	25	16,5	715	0,77	83,5	37,0			41	2,4					
	15	22,0	705	0,78	83,0	49,0			55	1,8					
SPEH 225 M8	100	15,0	728	0,66	86,0	38,0			42	3,6					
	60	17,5	725	0,70	86,0	42,0			49	3,1					
	40	20,0	720	0,73	85,5	47,0	0,0526	220	Y	56	2,7	1875	0,464	305	
	25	23,0	715	0,76	85,0	51,5			65	2,3					
	15	28,0	705	0,78	84,5	61,5			79	1,9					
SPEH 225 MX8	100	18,5	735	0,68	87,0	45,0			43	3,8					
	60	22,0	730	0,72	87,0	50,5			51	3,2					
	40	25,0	730	0,75	87,0	55,5	0,0606	270	Y	57	2,8	1875	0,568	330	
	25	28,0	725	0,77	87,0	60,5			64	2,5					
	15	35,0	720	0,78	86,0	75,5			80	2,0					
SPEH 250 M8	100	22	735	0,72	88,0	50,0			91	3,5					
	60	26	730	0,75	88,0	57,0			107	3,0					
	40	30	725	0,79	88,0	62,5	0,0134	150	Y	124	2,6	1875	1,00	425	
	25	34	725	0,80	88,0	70,0			140	2,3					
	15	42	720	0,81	87,0	86,0			173	1,9					

Drehstrommotoren mit Schleifringläufer für Aussetzbetrieb

Reihen SPEH und S11H
mit Oberflächenkühlung, Betriebsart S3,
Wärmeklasse F, Schutzart IP 54/IP 55

Motorauswahldaten											Bemessungspunkt 400 V, 50 Hz			
Typ	S3- %	P kW	n min ⁻¹	cos φ	η %	I 400 A	R Ω	Läufer		I A	M _k /M _B -	n _{max} min ⁻¹	J kgm ²	m kg
								U V						
Synchrondrehzahl 750 min ⁻¹ – 8-polige Ausführung														
S11H 250 MX8	100	27	740	0,77	90,0	56,0				88	3,4			
	60	32	737	0,78	90,0	66,0				104	2,9			
	40	37	735	0,79	90,0	75,0	0,0409	190	Δ	120	2,5	1875	1,78	600
	25	42	733	0,80	90,0	84,0				137	2,2			
	15	55	728	0,80	90,0	110				179	1,7			
S11H 280 S8	100	37	738	0,68	90,7	86,5				114	3,5			
	60	44	736	0,71	90,8	98,5				136	2,9			
	40	50	734	0,74	90,6	108	0,0328	200	Δ	154	2,6	1875	1,95	665
	25	57	732	0,76	90,2	120				176	2,3			
	15	70	730	0,78	89,9	144				216	1,9			
S11H 280 M8	100	45	740	0,69	91,3	103				111	3,6			
	60	55	737	0,74	91,3	118				136	3,0			
	40	63	735	0,77	91,2	130	0,0416	250	Δ	156	2,6	1875	2,37	710
	25	73	732	0,79	90,8	147				180	2,2			
	15	90	726	0,79	90,0	183				222	1,8			
S11H 315 S8	100	60	740	0,76	92,5	123				130	3,4			
	60	70	739	0,79	92,5	138				152	2,9			
	40	80	737	0,80	92,2	157	0,0317	285	Δ	173	2,5	1875	3,95	950
	25	93	735	0,82	91,7	179				202	2,2			
	15	105	733	0,82	90,5	204				228	1,9			
S11H 315 M8	100	75	740	0,77	91,9	153				129	3,1			
	60	88	738	0,80	91,8	173				151	2,6			
	40	100	735	0,80	91,5	197	0,0437	360	Δ	172	2,3	1875	4,31	1000
	25	115	732	0,81	91,0	225				198	2,0			
	15	140	730	0,81	90,0	277				240	1,6			
S11H 315 MX8	100	90	742	0,76	93,9	182				198	3,4			
	60	105	740	0,78	93,8	207				232	2,9			
	40	115	739	0,80	93,7	221	0,0066	280	Y	254	2,6	1875	6,8	1290
	25	140	736	0,81	93,2	268				309	2,2			
	15	160	733	0,81	92,5	308				353	1,9			
S11H 315 MY8	100	110	742	0,79	94,1	214				179	3,0			
	60	125	741	0,81	94,1	237				203	2,7			
	40	140	740	0,82	94,0	262	0,0090	380	Y	228	2,4	1875	8,1	1390
	25	160	739	0,83	93,7	297				260	2,1			
	15	190	735	0,82	92,5	362				309	1,8			
S11H 315 LX8	100	132	742	0,80	94,4	252				186	2,7			
	60	150	740	0,80	94,2	287				211	2,4			
	40	170	739	0,80	93,8	327	0,0100	440	Y	239	2,1	1875	9,8	1600
	25	195	737	0,81	93,4	372				274	1,8			
	15	220	735	0,81	93,3	420				309	1,6			

Drehstrommotoren mit Schleifringläufer für Aussetzbetrieb

Reihen SPEH und S11H
mit Oberflächenkühlung, Betriebsart S3,
Wärmeklasse F, Schutzart IP 54/IP 55

Motorauswahldaten											Bemessungspunkt 400 V, 50 Hz				
Typ	S3-	P	n	cos φ	η	I	R	Läufer	I	M _k /M _B	n _{max}	J	m		
	%	kW	min ⁻¹	%	%	400 V A	Ω	U V	A	-	min ⁻¹	kgm ²	kg		
Synchrondrehzahl 600 min ⁻¹ –10-polige Ausführung															
SPEH	250 M10	100	16,5	590	0,56	86,0	49,5			82	3,4				
		60	20,0	585	0,63	86,0	53,5			99	2,8				
		40	23,0	580	0,66	86,0	58,5	0,0113	125	Y	114	2,4	2000	0,937	425
		25	26,0	580	0,67	86,0	65,0			129	2,1				
		15	30,0	575	0,67	86,0	75,0			148	1,8				
S11H	250 MX10	100	20	590	0,52	84,5	66,0			82	3,6				
		60	24	587	0,57	85,0	71,0			99	2,8				
		40	28	585	0,62	86,0	76,0	0,0366	150	Δ	115	2,4	2000	1,61	580
		25	32	580	0,65	86,0	83,0			132	2,1				
		15	35	578						144	1,9				
S11H	280 S10	100	27	589	0,49	85,0	94,0			104	3,2				
		60	32	587	0,56	86,0	96,0			124	2,7				
		40	37	585	0,59	86,0	105	0,0282	160	Δ	143	2,3	2000	1,82	600
		25	42	580	0,63	86,0	112			162	2,0				
		15	48	575	0,67	87,0	149			185	1,7				
S11H	280 M10	100	35	589	0,55	86,0	107			111	2,9				
		60	42	587	0,60	87,0	116			133	2,4				
		40	48	585	0,64	87,0	124	0,0331	195	Δ	152	2,1	1500	2,37	710
		25	55	583	0,67	87,0	136			174	1,9				
		15	60	580						190	1,7				
S11H	315 S10	100	44	590	0,58	89,5	122			116	3,1				
		60	52	586	0,63	89,5	133			137	2,6				
		40	60	585	0,65	89,5	143	0,0383	235	Δ	158	2,2	1500	3,95	1000
		25	70	584	0,66	89,0	172			184	1,9				
		15	75	584	0,68	88,5	180			197	1,7				
S11H	315 M10	100	55	590	0,58	88,7	154			119	3,0				
		60	65	588	0,63	88,7	168			141	2,5				
		40	75	586	0,65	88,7	188	0,0395	285	Δ	163	2,1	1500	4,31	1050
		25	87	585	0,66	88,5	215			189	1,8				
		15	90	584	0,67	88,0	220								
S11H	315 MX10	100	70	589	0,60	91,0	185			160	2,7				
		60	80	588	0,64	91,0	198			183	2,3				
		40	90	587	0,66	91,0	216	0,0099	270	Y	206	2,1	1500	6,8	1290
		25	100	585	0,68	90,8	234			229	1,9				
S11H	315 MY10	100	80	593	0,64	92,3	196			157	2,9				
		60	90	592	0,67	92,3	210			177	2,6				
		40	100	590	0,68	92,3	230	0,0258	315	Δ	196	2,3	1500	8,1	1390
		25	120	588	0,68	91,5	280			235	1,9				
S11H	315 LX10	100	90	592	0,66	92,7	212			159	2,6				
		60	105	590	0,69	92,6	237			185	2,2				
		40	115	589	0,71	92,4	253	0,0310	350	Δ	203	2,0	1500	9,8	1600
		25	135	585	0,72	91,0	297			238	1,7				

Drehstrommotoren mit Schleifringläufer für Aussetzbetrieb

Reihen SPEH und S11H
 mit Oberflächenkühlung, Betriebsart S4 und S5, mittleres Anlaufmoment $M_A = 1,5 \cdot M_N$
 Wärmeklasse F, Schutzart IP 54/IP 55

Motorauswahldaten										Bemessungspunkt 400 V, 50 Hz		
Typ	S4/S5- %	c/h	P kW	n min ⁻¹	Läufer			I A	M _K /M _B -	J _{Motor} kgm ²	J _{Fremd} kgm ²	m kg
					R Ω	U V						
Synchrondrehzahl 1500 min ⁻¹ – 4-polige Ausführung												
SPEH 132 M4	60	150	4,8	1450				18,5	3,4			
	40	150	5,8	1440				22,2	2,8			
	25	150	6,4	1430	0,1141	160	Y	24,7	2,6	0,043	0,086	85
	60	300	4,1	1455				15,9	4,0			
	40	300	4,8	1450				18,5	3,4			
SPEH 132 MX4	60	600	3,2	1475				12,2	5,2			
	60	150	5,5	1450				18,9	3,7			
	40	150	6,6	1440				22,7	3,1			
	25	150	7,3	1435	0,1168	180	Y	25,0	2,8	0,050	0,100	95
	60	300	4,7	1455				16,2	4,3			
SPEH 160 M4	40	300	5,5	1450				18,9	3,7			
	60	600	3,6	1470				12,5	5,6			
	60	150	7,5	1460				25,5	4,0			
	40	150	9,0	1450				31,0	3,3			
	25	150	10,0	1445	0,0792	180	Y	34,5	3,0	0,093	0,186	133
SPEH 160 L4	60	300	6,5	1465				22,1	4,7			
	40	300	7,5	1460				25,5	4,0			
	60	600	5,0	1470				17,0	6,1			
	60	150	11,0	1465				26,0	4,6			
	40	150	13,2	1460				31,5	3,8			
SPEH 180 L4	25	150	14,7	1455				35,0	3,5			
	60	300	9,5	1470	0,0919	260	Y	22,5	5,3	0,128	0,256	150
	40	300	11,0	1465				26,0	4,6			
	60	600	7,3	1478				17,2	7,0			
	60	150	15,0	1470				34,5	4,6			
SPEH 200 L4	40	150	18,0	1465				41,0	3,8			
	25	150	20,0	1460	0,0639	270	Y	45,5	3,5	0,195	0,351	204
	60	300	12,9	1475				29,5	5,3			
	40	300	15,0	1470				34,5	4,6			
	60	600	9,9	1477				22,7	7,0			
SPEH 200 LX4	60	150	18,5	1470				49,5	4,4			
	40	150	22,0	1465				60,0	3,7			
	25	150	24,5	1460	0,0344	230	Y	66,0	3,3	0,330	0,561	280
	60	300	16,0	1473				42,5	5,1			
	40	300	18,5	1470				49,5	4,4			
SPEH 225 M4	60	600	12,0	1478				33,0	6,8			
	60	150	22,0	1475				49,5	4,2			
	40	150	26,6	1470				59,5	3,5			
	25	150	29,0	1465	0,0377	275	Y	66,0	3,2	0,403	0,605	305
	60	300	19,0	1477				42,7	4,9			
SPEH 250 M4	40	300	22,0	1475				49,5	4,2			
	60	600	14,5	1482				32,5	6,4			
	60	150	30,0	1475				56,0	4,9			
	40	150	36,0	1460				67,5	4,1			
	25	150	40,0	1465	0,0367	330	Y	75,0	3,7	0,476	0,714	330
SPEH 250 M4	60	300	26,0	1480				48,5	5,7			
	40	300	30,0	1475				56,0	4,9			
	60	600	20,0	1485				37,0	7,4			
	60	150	37	1482				117	4,5			
	40	150	44,5	1478				141	3,7			
SPEH 250 M4	25	150	49,5	1475	0,0083	195	Y	157	3,4	0,568	0,795	425
	60	300	32,0	1485				101	5,2			
	40	300	37,0	1482				117	4,5			
	60	600	24,5	1490				78	6,8			

Drehstrommotoren mit Schleifringläufer für Aussetzbetrieb

Reihen SPEH und S11H
mit Oberflächenkühlung, Betriebsart S4 und S5, mittleres Anlaufmoment $M_A = 1,5 \cdot M_N$
Wärmeklasse F, Schutzart IP 54/IP 55

Motorauswahldaten										Bemessungspunkt 400 V, 50 Hz		
Typ	S4/S5- %	c/h	P kW	n min ⁻¹	Läufer			I A	M _K /M _B -	J _{Motor} kgm ²	J _{Fremd} kgm ²	m kg
					R Ω	U V						
Synchrondrehzahl 1500 min ⁻¹ – 4-polige Ausführung												
SPEH 250 MX4	60	150	45,0	1480				118	4,2			
	40	150	54,0	1477				142	3,5			
	25	150	60,0	1475	0,0105	235	Y	158	3,2	0,632	0,758	450
	60	300	38,5	1484				101	4,9			
	40	300	45,0	1480				118	4,2			
S11H 280 S4	60	600	29,5	1486				78	6,4			
	60	150	60	1480				154	4,0			
	40	150	72	1477				185	3,3			
	25	150	80	1473	0,0086	240	Y	206	3,0	1,25	1,25	590
	60	300	51	1484				131	4,7			
S11H 280 M4	40	300	60	1480				154	4,0			
	60	600	40	1486				103	6,0			
	60	150	75	1486				149	5,2			
	40	150	90	1484				179	4,3			
	25	150	100	1482	0,0239	310	Δ	199	3,9	1,85	1,85	710
S11H 315 S4	60	300	65	1488				129	6,0			
	40	300	75	1486				149	5,2			
	60	600	50	1490				99	7,9			
	60	150	90	1488				179	5,8			
	40	150	108	1486				215	4,8			
S11H 315 M4	25	150	120	1484	0,0177	310	Δ	239	4,4	2,85	2,00	890
	60	300	77	1490				154	6,7			
	40	300	90	1488				179	5,8			
	60	600	59	1492				118	8,8			
	60	150	110	1485				181	5,4			
S11H 315 MX4	40	150	132	1483				217	4,5			
	25	150	147	1481	0,0210	375	Δ	242	4,1	3,48	2,44	1010
	60	300	95	1488				156	6,3			
	40	300	110	1485				181	5,4			
	60	600	73	1492				120	8,2			
S11H 315 MY4	60	150	132	1488				199	5,3			
	40	150	158	1486				239	4,4			
	25	150	176	1484	0,0180	410	Δ	265	4,0	5,32	2,66	1275
	60	300	114	1489				171	6,2			
	40	300	132	1488				199	5,3			
S11H 315 LX4	60	600	87	1492				131	8,0			
	60	150	160	1488				196	5,3			
	40	150	192	1485				235	4,4			
	25	150	213	1484	0,0073	505	Y	261	4,0	5,96	2,68	1350
	60	300	138	1489				168	6,2			
S11H 315 LY4	40	300	160	1488				196	5,3			
	60	600	106	1492				129	8,0			
	60	150	200	1490				193	5,3			
	40	150	240	1488				232	4,4			
	25	150	267	1487	0,0264	640	Δ	257	4,0	7,29	2,92	1540
S11H 315 LX4	60	300	172	1491				166	6,2			
	40	300	200	1490				193	5,3			
	60	600	132	1493				127	8,0			
	60	150	250	1488				213	4,5			
	40	150	300	1483				256	3,8			
S11H 315 LY4	25	150	333	1480	0,0273	725	Δ	284	3,4	8,06	3,22	1620
	60	300	215	1490				183	5,2			
	40	300	250	1488				213	4,5			
	60	600	165	1492				141	6,8			

Drehstrommotoren mit Schleifringläufer für Aussetzbetrieb

Reihen SPEH und S11H
 mit Oberflächenkühlung, Betriebsart S4 und S5, mittleres Anlaufmoment $M_A = 1,5 * M_N$
 Wärmeklasse F, Schutzart IP 54/IP 55

Motorauswahldaten										Bemessungspunkt 400 V, 50 Hz		
Typ	S4/S5- %	c/h	P kW	n min ⁻¹	Läufer			I A	M _K /M _B -	J _{Motor} kgm ²	J _{Fremd} kgm ²	m kg
					R Ω	U V	Y					
Synchrondrehzahl 1000 min ⁻¹ – 6-polige Ausführung												
SPEH 132 M6	60	150	3,5	945				18,0	3,1			
	40	150	4,2	938				21,6	2,6			
	25	150	4,7	930	0,1180	120	Y	24,0	2,3	0,050	0,100	85
	60	300	3,0	950				15,5	3,6			
	40	300	3,5	945				18,0	3,1			
SPEH 132 MX6	60	600	2,3	960				11,9	4,7			
	60	150	4,0	965				17,7	3,7			
	40	150	4,8	955				21,2	3,1			
	25	150	5,3	950	0,1151	140	Y	23,5	2,8	0,063	0,126	95
	60	300	3,4	970				15,2	4,3			
SPEH 160 M6	40	300	4,0	965				17,7	3,7			
	60	600	2,6	973				11,6	5,6			
	60	150	5,5	973				18,9	4,2			
	40	150	6,6	967				22,7	3,5			
	25	150	7,3	963	0,1097	180	Y	25,0	3,2	0,135	0,270	133
SPEH 160 L6	60	300	4,7	977				16,2	4,9			
	40	300	5,5	973				18,9	4,2			
	60	600	3,6	982				12,5	6,4			
	60	150	7,5	972				17,8	3,8			
	40	150	9,0	967				21,4	3,2			
SPEH 180 L6	25	150	10,0	965	0,1600	260	Y	23,8	2,9	0,162	0,324	165
	60	300	6,5	976				15,3	4,4			
	40	300	7,5	972				17,8	3,8			
	60	600	5,0	980				11,8	5,8			
	60	150	11,0	968				29,5	3,8			
SPEH 200 L6	40	150	13,2	960				35,5	3,2			
	25	150	14,7	957	0,0959	230	Y	39,5	2,9	0,279	0,558	204
	60	300	9,5	972				25,5	4,4			
	40	300	11,0	968				29,5	3,8			
	60	600	7,3	983				19,5	5,8			
SPEH 225 M6	60	150	15	973				36,5	3,6			
	40	150	18,0	967				43,5	3,0			
	25	150	20,0	963	0,0754	255	Y	48,5	2,7	0,371	0,742	280
	60	300	12,9	977				31,5	4,2			
	40	300	15,0	973				36,5	3,6			
SPEH 225 MX6	60	600	9,9	982				24,0	5,5			
	60	150	18,5	978				45,5	4,3			
	40	150	22,2	973				55,0	3,6			
	25	150	24,7	970	0,0499	250	Y	61,0	3,2	0,464	0,928	305
	60	300	15,9	981				39,5	5,0			
SPEH 250 M6	40	300	18,5	978				45,5	4,3			
	60	600	12,2	986				30,0	6,5			
	60	150	22,0	980				47,0	3,9			
	40	150	26,5	975				56,0	3,2			
	25	150	29,0	970	0,0561	290	Y	62,0	3,0	0,535	1,07	320
SPEH 250 MX6	60	300	19,0	982				40,5	4,5			
	40	300	22,0	980				47,0	3,9			
	60	600	14,5	985				31,0	5,9			
	60	150	27,0	980				119	4,2			
	40	150	32,0	980				141	3,5			
SPEH 250 M6	25	150	36,0	980	0,0103	140	Y	159	3,2	1,00	1,50	425
	60	300	23,0	984				101	4,9			
	40	300	27,0	980				119	4,2			
	60	600	17,0	988				75	6,7			

Drehstrommotoren mit Schleifringläufer für Aussetzbetrieb

Reihen SPEH und S11H
mit Oberflächenkühlung, Betriebsart S4 und S5, mittleres Anlaufmoment $M_A = 1,5 * M_N$
Wärmeklasse F, Schutzart IP 54/IP 55

Motorauswahldaten		Bemessungspunkt 400 V, 50 Hz										
Typ	S4/S5- %	c/h	P kW	n min ⁻¹	Läufer			I A	M _K /M _B -	J _{Motor} kgm ²	J _{Fremd} kgm ²	m kg
					R Ω	U V	Δ					
Synchrondrehzahl 1000 min ⁻¹ – 6-polige Ausführung												
S11H 250 MX6	60	150	34,0	987				120	4,4			
	40	150	40,0	986				141	3,7			
	25	150	45,0	985	0,0261	175	Δ	159	3,3	1,61	2,25	580
	60	300	29,0	988				102	5,2			
	40	300	34,0	987				120	4,4			
	60	600	22,0	990				78	6,8			
S11H 280 S6	60	150	45	987				146	4,2			
	40	150	54	984				176	3,5			
	25	150	60	982	0,0248	190	Δ	195	3,2	1,82	2,28	600
	60	300	39	989				126	4,9			
	40	300	45	987				146	4,2			
	60	600	30	990				97	6,4			
S11H 280 M6	60	150	55	986				145	4,0			
	40	150	66	983				173	3,3			
	25	150	73	980	0,0273	235	Δ	193	3,0	2,37	2,84	700
	60	300	47	988				124	4,7			
	40	300	55	986				145	4,0			
	60	600	36	991				95	6,1			
S11H 315 S6	60	150	75	990				178	4,1			
	40	150	90	988				214	3,4			
	25	150	100	987	0,0175	260	Δ	238	3,1	3,95	3,95	950
	60	300	65	991				153	4,8			
	40	300	75	990				178	4,1			
	60	600	50	992				118	6,2			
S11H 315 M6	60	150	90	988				179	4,0			
	40	150	108	986				215	3,3			
	25	150	120	984	0,0241	310	Δ	239	3,0	4,31	4,09	1000
	60	300	77	990				154	4,7			
	40	300	90	988				179	4,0			
	60	600	59	992				118	6,1			
S11H 315 MX6	60	150	110	987				197	3,5			
	40	150	132	985				236	2,9			
	25	150	147	983	0,0070	345	Y	263	2,6	6,8	5,8	1290
	60	300	95	989				169	4,1			
	40	300	110	987				197	3,5			
	60	600	73	991				130	5,3			
S11H 315 MY6	60	150	132	989				183	3,6			
	40	150	158	985				220	3,0			
	25	150	176	986	0,0100	445	Y	244	2,7	8,0	6,4	1380
	60	300	114	990				158	4,2			
	40	300	132	989				183	3,6			
	60	600	87	992				121	5,5			
S11H 315 LX6	60	150	160	990				192	3,5			
	40	150	192	989				230	2,9			
	25	150	213	988	0,0101	515	Y	256	2,6	9,6	7,2	1590
	60	300	138	992				165	4,1			
	40	300	160	990				192	3,5			
	60	600	106	993				127	5,3			

Drehstrommotoren mit Schleifringläufer für Aussetzbetrieb

Reihen SPEH und S11H
 mit Oberflächenkühlung, Betriebsart S4 und S5, mittleres Anlaufmoment $M_A = 1,5 * M_N$
 Wärmeklasse F, Schutzart IP 54/IP 55

Motorauswahldaten										Bemessungspunkt 400 V, 50 Hz			
Typ	S4/S5- %	c/h	P kW	n min ⁻¹	R Ω	Läufer		I A	M _K /M _B -	J _{Motor} kgm ²	J _{Fremd} kgm ²	m kg	
						U V	Y						
Synchrondrehzahl 750 min ⁻¹ – 8-polige Ausführung													
SPEH 132 M8	60	150	2,3	710					9,8	2,9			
	40	150	2,8	700					11,8	2,4			
	25	150	3,1	690	0,3030	145	Y		13,1	2,2	0,048	0,144	
	60	300	2,0	715					8,4	3,4		85	
	40	300	2,3	710					9,8	2,9			
60	600	1,5	720					6,5	4,4				
SPEH 132 MX8	60	150	3,0	710					11,6	3,0			
	40	150	3,6	700					13,9	2,5			
	25	150	4,0	695	0,2800	160	Y		15,4	2,3	0,058	0,174	
	60	300	2,6	712					10,0	3,5		95	
	40	300	3,0	710					11,6	3,0			
60	600	2,0	715					7,6	4,5				
SPEH 160 M8	60	150	3,6	725					11,7	3,0			
	40	150	4,3	722					14,0	2,5			
	25	150	4,8	718	0,1980	190	Y		15,6	2,3	0,135	0,405	
	60	300	3,1	727					10,1	3,5		133	
	40	300	3,6	725					11,7	3,0			
60	600	2,4	733					7,7	4,5				
SPEH 160 L8	60	150	5,5	730					17,0	3,3			
	40	150	6,6	723					20,4	2,8			
	25	150	7,3	720	0,1590	200	Y		22,6	2,5	0,162	0,486	
	60	300	4,7	734					14,6	3,8		145	
	40	300	5,5	730					17,0	3,3			
60	600	3,6	736					11,2	5,0				
SPEH 180 L8	60	150	7,5	725					22,1	3,7			
	40	150	9,0	718					26,5	3,1			
	25	150	10,0	715	0,1312	210	Y		29,5	2,8	0,279	0,698	
	60	300	6,5	727					19,0	4,3		204	
	40	300	7,5	725					22,1	3,7			
60	600	5,0	733					14,6	5,6				
SPEH 200 L8	60	150	11,0	728					27,0	3,5			
	40	150	13,2	722					32,5	2,9			
	25	150	14,7	720	0,0977	250	Y		36,0	2,6	0,279	0,698	
	60	300	9,5	732					23,4	4,1		280	
	40	300	11,0	728					27,0	3,5			
60	600	7,3	736					17,9	5,3				
SPEH 225 M8	60	150	15,0	728					42,0	3,6			
	40	150	18,0	724					50,5	3,0			
	25	150	20,0	720	0,0526	220	Y		65,0	2,7	0,464	0,928	
	60	300	12,9	730					36,0	4,2		305	
	40	300	15,0	728					42,0	3,6			
60	600	9,9	735					28,0	5,5				
SPEH 225 MX8	60	150	18,5	735					42,5	3,8			
	40	150	22,2	730					51,0	3,2			
	25	150	24,5	730	0,0606	270	Y		56,5	2,9	0,568	1,14	
	60	300	16,0	735					36,5	4,4		330	
	40	300	18,5	735					42,5	3,8			
60	600	12,0	738					28,0	5,9				
SPEH 250 M8	60	150	22,0	735					91	3,5			
	40	150	26,0	730					107	3,0			
	25	150	29,0	725	0,0134	150	Y		119	2,7	1,00	2,00	
	60	300	19,0	738					78	4,1		425	
	40	300	22,0	735					91	3,5			
60	600	14,5	740					60	5,3				

Drehstrommotoren mit Schleifringläufer für Aussetzbetrieb

Reihen SPEH und S11H
mit Oberflächenkühlung, Betriebsart S4 und S5, mittleres Anlaufmoment $M_A = 1,5 * M_N$
Wärmeklasse F, Schutzart IP 54/IP 55

Motorauswahldaten										Bemessungspunkt 400 V, 50 Hz		
Typ	S4/S5-	c/h	P	n	R	Läufer		I	M_K/M_B	J_{Motor}	J_{Fremd}	m
	%		kW	min ⁻¹	Ω	U V		A	-	kgm ²	kgm ²	kg
Synchrondrehzahl 750 min ⁻¹ – 8-polige Ausführung												
S11H 250 MX8	60	150	27,0	740				88	3,4			
	40	150	32,0	737				104	2,9			
	25	150	36,0	735	0,0409	190	Δ	117	2,6	1,78	3,56	600
	60	300	23,0	741				75	4,0			
	40	300	27,0	740				88	3,4			
S11H 280 S8	60	600	17,5	743				57	5,2			
	60	150	37	738				114	3,5			
	40	150	44	736				136	2,9			
	25	150	49	734	0,0328	200	Δ	151	2,6	1,95	3,90	665
	60	300	32	740				99	4,0			
S11H 280 M8	40	300	37	738				114	3,5			
	60	600	24	743				74	5,4			
	60	150	45	740				111	3,6			
	40	150	54	737				133	3,0			
	25	150	60	734	0,0416	250	Δ	148	2,7	2,37	4,74	710
S11H 315 S8	60	300	39	742				96	4,2			
	40	300	45	740				111	3,6			
	60	600	30	744				73	5,5			
	60	150	60	740				130	3,4			
	40	150	72	739				156	2,8			
S11H 315 M8	25	150	80	737	0,0317	285	Δ	173	2,6	3,95	7,9	950
	60	300	52	742				112	4,0			
	40	300	60	740				130	3,4			
	60	600	40	744				86	5,2			
	60	150	75	740				129	3,1			
S11H 315 MX8	40	150	90	738				154	2,6			
	25	150	100	735	0,0437	360	Δ	172	2,3	4,31	8,6	1000
	60	300	65	742				111	3,6			
	40	300	75	740				129	3,1			
	60	600	50	744				85	4,7			
S11H 315 MY8	60	150	90	742				199	3,4			
	40	150	108	740				238	2,8			
	25	150	120	739	0,0066	280	Y	265	2,6	6,8	11,6	1290
	60	300	77	743				171	4,0			
	40	300	90	742				199	3,4			
S11H 315 LX8	60	600	59	744				131	5,2			
	60	150	110	742				179	3,0			
	40	150	132	741				215	2,5			
	25	150	147	740	0,0090	380	Y	238	2,3	8,1	13,0	1390
	60	300	95	743				154	3,5			
S11H 315 LX8	40	300	110	742				179	3,0			
	60	600	73	744				118	4,5			
	60	150	132	742				185	2,7			
	40	150	158	740				222	2,3			
	25	150	176	739	0,0100	440	Y	247	2,0	9,8	13,7	1600
S11H 315 LX8	60	300	114	743				159	3,1			
	40	300	132	742				185	2,7			
	60	600	87	744				122	4,1			

Drehstrommotoren mit Schleifringläufer für Aussetzbetrieb

Reihen SPEH und S11H
 mit Oberflächenkühlung, Betriebsart S4 und S5, mittleres Anlaufmoment $M_A = 1,5 \cdot M_N$
 Wärmeklasse F, Schutzart IP 54/IP 55

Motorauswahldaten		Bemessungspunkt 400 V, 50 Hz											
Typ	S4/S5- %	c/h	P kW	n min ⁻¹	Läufer			I A	M _K /M _B -	J _{Motor} kgm ²	J _{Fremd} kgm ²	m kg	
					R Ω	U V							
Synchrondrehzahl 600 min ⁻¹ – 10-polige Ausführung													
SPEH	250 M10	60	150	16,5	590				82	3,4			
		40	150	19,8	585				98	2,8			
		25	150	22,0	580	0,0113	125	Y	109	2,6	0,937	1,87	425
		60	300	14,2	591				70	4,0			
		40	300	16,5	590				82	3,4			
S11H	250 MX10	60	600	10,9	593				54	5,2			
		60	150	20,0	590				82	3,6			
		40	150	24,0	587				99	3,0			
		25	150	26,7	585	0,0366	150	Δ	110	2,7	1,61	3,22	580
		60	300	17,2	591				71	4,2			
S11H	280 S10	40	300	20,0	590				82	3,6			
		60	600	13,2	593				54	5,5			
		60	150	27,0	589				104	3,2			
		40	150	32,0	587				124	2,7			
		25	150	36,0	585	0,0282	160	Δ	139	2,4	1,82	3,64	600
S11H	280 M10	60	300	23,0	590				89	3,8			
		40	300	27,0	589				104	3,2			
		60	600	17,5	592				68	4,9			
		60	150	35,0	589				111	2,9			
		40	150	42,0	587				133	2,4			
S11H	315 S10	25	150	46,0	585	0,0331	195	Δ	146	2,2	2,37	4,74	710
		60	300	30,0	590				95	3,4			
		40	300	35,0	589				111	2,9			
		60	600	23,0	592				73	4,4			
		60	150	44	592				116	3,1			
S11H	315 M10	40	150	53	590				139	2,6			
		25	150	58	588	0,0383	235	Δ	152	2,4	3,95	7,11	950
		60	300	37	593				97	3,7			
		40	300	44	952				116	3,1			
		60	600	29	594				76	4,7			
S11H	315 MX10	60	150	55	590				119	3,0			
		40	150	66	588				143	2,5			
		25	150	73	586	0,0395	285	Δ	159	2,3	4,31	7,76	1000
		60	300	47	591				103	3,5			
		40	300	55	590				119	3,0			
S11H	315 MY10	60	600	36	592				79	4,5			
		60	150	70	589				160	2,7			
		40	150	80	588				183	2,3			
		25	150	93	587	0,0099	270	Y	213	2,0	6,8	13,6	1290
		60	300	58	591				133	3,2			
S11H	315 LX10	40	300	70	589				160	2,7			
		60	600	45	593				103	4,2			
		60	150	80	593				157	2,9			
		40	150	90	592				177	2,6			
		25	150	105	590	0,0258	315	Δ	206	2,2	8,1	16,2	1390
S11H	315 MY10	60	300	65	594				128	3,6			
		40	300	80	593				157	2,9			
		60	600	50	595				98	4,7			
		60	150	90	592				159	2,6			
		40	150	105	590				185	2,2			
S11H	315 LX10	25	150	115	589	0,0310	350	Δ	203	2,0	9,8	19,6	1600
		60	300	75	593				132	3,1			
		40	300	90	592				159	2,6			
		60	600	58	594				102	4,0			

Drehstrommotoren mit Schleifringläufer für Aussetzbetrieb

Reihen SPH und S10H, progressive Leistungszuordnung
mit Oberflächenkühlung, Betriebsart S3
Wärmeklasse F, Schutzart IP 54/IP 55

Motorauswahldaten											Bemessungspunkt 400 V, 50 Hz		
Typ	S3- %	P kW	n min ⁻¹	I 400 V A	R Ω	Läufer		I A	M _K /M _B -	n _{max} min ⁻¹	J kgm ²	m kg	
						U V	Y						
Synchrondrehzahl 1500 min ⁻¹ – 4-polige Ausführung													
SPH 132 M4	100	4,5	1435	10,0				17,5	2,8				
	60	5,4	1420	12,0				21,0	2,4				
	40	6,0	1410	13,0	0,1480	160	Y	23,0	2,1	2500	0,038	85	
	25	6,9	1390	15,0				27,0	1,8				
SPH 132 MX4	100	5,7	1450	13,0				18,5	3,7				
	60	6,9	1440	15,0				22,5	3,4				
	40	7,7	1430	16,0	0,1380	190	Y	25,0	2,7	2500	0,043	95	
	25	8,9	1415	19,5				29,0	2,3				
SPH 132 L4	100	7,0	1455	16,5				22,0	3,8				
	60	8,5	1445	19,0				27,0	3,1				
	40	9,5	1440	20,5	0,1150	200	Y	30,0	2,8	2500	0,060	105	
	25	11,0	1430	23,5				34,0	2,4				
SPH 160 M4	100	10,0	1460	22,5				30,0	4,6				
	60	12,5	1450	25,5				38,0	3,7				
	40	15,0	1440	30,0	0,0583	205	Y	45,0	3,0	2400	0,128	150	
	25	16,5	1430	32,5				50,0	2,7				
SPH 160 L4	100	12,5	1470	27,5				34,5	5,2				
	60	15,5	1460	31,5				43,0	4,2				
	40	18,0	1455	35,0	0,0450	225	Y	50,0	3,6	2400	0,145	165	
	25	22,0	1445	42,5				60,0	2,9				
SPH 180 M4	100	18,5	1465	34,5				49,5	4,5				
	60	21,0	1460	38,5				57,0	4,0				
	40	24,0	1455	43,5	0,0422	230	Y	65,0	3,5	2200	0,250	225	
	25	28,0	1450	51,0				75,0	3,0				
SPH 180 L4	100	22,0	1465	40,5				50,5	4,1				
	60	25,0	1460	45,5				57,5	3,6				
	40	28,0	1455	51,0	0,0438	270	Y	64,0	3,2	2200	0,285	255	
	25	33,0	1450	59,0				75,5	2,7				
SPH 180 L4	15	40,0	1440	73,0				91,5	2,2				

Drehstrommotoren mit Schleifringläufer für Aussetzbetrieb

Reihen SPH und S10H, progressive Leistungszuordnung
 mit Oberflächenkühlung, Betriebsart S3
 Wärmeklasse F, Schutzart IP 54/IP 55

Motorauswahldaten										Bemessungspunkt 400 V, 50 Hz			
Typ		S3- %	P kW	n min ⁻¹	I 400 V A	R Ω	Läufer U V		I A	M _K /M _B -	η _{max} min ⁻¹	J kgm ²	m kg
Synchrondrehzahl 1500 min ⁻¹ – 4-polige Ausführung													
SPH	200 M4	100	30,0	1475	58,0				56,0	4,9			
		60	34,0	1470	64,0				64,0	4,3			
		40	39,0	1465	72,0	0,3670	330	Y	73,0	3,8	2200	0,476	330
		25	45,0	1460	82,0				84,0	3,3			
		15	53,0	1455	98,0				99,0	2,8			
SPH	200 L4	100	37,0	1480	70,0				78,0	5,1			
		60	42,0	1475	78,0				88,0	4,5			
		40	48,0	1473	87,0	0,0229	295	Y	101,0	3,9	2200	0,590	375
		25	55,0	1470	88,5				115,0	3,4			
		15	65,0	1465	117,0				136,0	2,9			
SPH	225 M4	100	45,0	1480	82,5				118,0	4,2			
		60	51,0	1478	91,5				134,0	3,7			
		40	58,0	1475	103,0	0,0105	235	Y	152,0	3,3	2200	0,632	450
		25	67,0	1470	117,0				176,0	2,8			
		15	80,0	1465	138,0				210,0	2,4			
S10H	250 M4	100	60,0	1480	112,0				154,0	4,4			
		60	68,0	1475	124,0				175,0	3,8			
		40	75,0	1475	135,0	0,00859	240	Y	193,0	3,5	2200	1,030	590
		25	90,0	1470	159,0				232,0	2,9			
		15	105	1465	188,0				270,0	2,5			
S10H	250 L4	100	75,0	1486	145,0				149,0	5,7			
		60	85,0	1484	160,0				169,0	5,0			
		40	95,0	1483	174,0	0,0239	310	Δ	189,0	4,5	2200	1,850	710
		25	110	1480	199,0				219,0	3,9			
		15	132	1478	233,0				263,0	3,2			
S10H	280 M4	100	90,0	1488	158,0				179,0	5,8			
		60	100	1487	173,0				199,0	5,3			
		40	115	1485	195,0	0,0181	310	Δ	229,0	4,6	2200	2,850	890
		25	132	1483	221,0				263,0	4,0			
		15	160	1479	268,0				319,0	3,3			
S10H	280 L4	100	110	1485	185,0				181,0	5,4			
		60	125	1483	208,0				206,0	4,8			
		40	140	1482	230,0	0,0210	375	Δ	231,0	4,3	2200	3,480	1010
		25	160	1480	264,0				264,0	3,7			
		15	190	1475	310,0				313,0	3,1			

Drehstrommotoren mit Schleifringläufer für Aussetzbetrieb

Reihen SPH und S10H, progressive Leistungszuordnung
mit Oberflächenkühlung, Betriebsart S3
Wärmeklasse F, Schutzart IP 54/IP 55

Motorauswahldaten										Bemessungspunkt 400 V, 50 Hz		
Typ	S3- %	P kW	n min ⁻¹	I 400 V A	R Ω	Läufer U V	I A	M _k /M _B -	η _{max} min ⁻¹	J kgm ²	m kg	
Synchrondrehzahl 1000 min ⁻¹ – 6-polige Ausführung												
SPH 132 M6	100	3,3	950	8,0			13,0	2,9				
	60	4,0	935	9,6			15,5	2,4				
	40	4,8	915	11,5	0,2210	160	Y	18,5	1,9	2500	0,050	85
	25	5,4	900	12,5			21,0	1,7				
	15	5,4	900	12,5			21,0	1,7				
SPH 132 MX6	100	4,3	960	10,5			15,0	3,2				
	60	5,2	950	12,0			18,0	2,6				
	40	6,2	935	13,5	0,1920	180	Y	21,0	2,2	2500	0,063	95
	25	7,0	925	15,5			24,0	1,9				
	15	7,6	915	17,0			26,0	1,8				
SPH 132 L6	100	5,0	960	12,5			15,0	3,5				
	60	6,2	945	14,5			18,0	2,8				
	40	7,3	935	17,0	0,2045	210	Y	21,5	2,4	2500	0,078	105
	25	8,3	930	19,0			24,5	2,1				
	15	9,0	920	20,0			26,5	1,9				
SPH 160 M6	100	7,7	970	18,5			22,0	3,7				
	60	9,0	965	20,5			26,0	3,1				
	40	10,5	960	23,0	0,1030	215	Y	30,0	2,7	2400	0,162	145
	25	12,5	955	26,5			36,0	2,2				
	15	13,5	950	28,5			39,0	2,0				
SPH 160 L6	100	11,0	975	27,0			33,0	4,0				
	60	13,0	975	30,0			38,0	3,4				
	40	15,0	970	33,0	0,0582	210	Y	44,0	2,9	2400	0,203	165
	25	17,5	965	38,0			52,0	2,5				
	15	20,0	960	42,5			59,0	2,2				
SPH 180 M6	100	14,5	975	33,0			39,0	4,0				
	60	16,5	970	36,0			44,0	3,5				
	40	20,0	965	42,0	0,0589	230	Y	54,0	2,9	2200	0,315	225
	25	22,0	960	45,5			59,0	2,6				
	15	27,0	950	54,5			73,0	2,1				
SPH 180 L6	100	16,0	980	37,0			40,0	4,6				
	60	19,0	975	41,5			47,0	3,9				
	40	23,0	970	47,5	0,0527	250	Y	57,0	3,2	2200	0,358	255
	25	26,0	960	52,5			64,0	2,8				
	15	32,0	950	63,0			79,0	2,3				
SPH 200 M6	100	22,0	975	44,0			62,0	3,8				
	60	26,0	970	51,0			73,0	3,2				
	40	32,0	965	61,0	0,0350	220	Y	90,0	2,6	2080	0,535	320
	25	35,0	960	66,0			99,0	2,4				
	15	40,0	955	69,5			113,0	2,1				
SPH 225 M6	100	30,0	980	58,0			77,0	3,7				
	60	36,0	980	69,0			93,0	3,1				
	40	42,0	975	79,5	0,0231	240	Y	108,0	2,6	2080	1,000	425
	25	48,0	970	89,5			124,0	2,3				
	15	55,0	965	103,0			142,0	2,0				
S10H 250 M6	100	37,0	980	70,5			102,0	3,6				
	60	45,0	980	83,5			124,0	3,0				
	40	52,0	975	96,0	0,0373	225	Δ	143,0	2,6	2080	1,610	580
	25	58,0	970	107,0			160,0	2,3				
	15	68,0	965	127,0			187,0	2,0				
S10H 250 MX6	100	45,0	985	88,0			116,0	3,9				
	60	54,0	985	104,0			139,0	3,2				
	40	63,0	980	118,0	0,0357	240	Δ	163,0	2,8	2080	1,820	600
	25	70,0	975	129,0			180,0	2,5				
	15	80,0	975	148,0			206,0	2,2				
S10H 280 M6	100	55,0	988	103,0			131,0	4,0				
	60	67,0	985	122,0			160,0	3,2				
	40	80,0	980	144,0	0,0305	260	Δ	190,0	2,7	2080	3,100	850
	25	90,0	980	162,0			212,0	2,4				
	15	105	975	190,0			250,0	2,1				
S10H 280 L6	100	75,0	990	143,0			160,0	4,1				
	60	85,0	988	158,0			180,0	3,6				
	40	100	985	181,0	0,0239	290	Δ	212,0	3,1	2080	3,620	950
	25	112	985	201,0			238,0	2,8				
	15	130	980	233,0			277,0	2,4				

Drehstrommotoren mit Schleifringläufer für Aussetzbetrieb

Reihen SPH und S10H, progressive Leistungszuordnung
mit Oberflächenkühlung, Betriebsart S3
Wärmeklasse F, Schutzart IP 54/IP 55

Motorauswahldaten										Bemessungspunkt 400 V, 50 Hz				
Typ		S3- %	P kW	n min ⁻¹	I 400 V A	R Ω	Läufer U V		I A	M _K /M _B -	η _{max} min ⁻¹	J kgm ²	m kg	
Synchrondrehzahl 750 min ⁻¹ – 8-polige Ausführung														
SPH	132 M8	100	2,3	710	7,7				10,0	2,9				
		60	2,8	700	8,5				12,5	2,3				
		40	3,3	685	9,4	0,3030	145	Y	15,0	2,0	2500	0,048	85	
		25	3,3	685	9,4				15,0	2,0				
		15	3,3	685	9,4				15,0	2,0				
SPH	132 MX8	100	3,0	710	9,4				11,5	3,0				
		60	3,6	700	10,5				14,0	2,5				
		40	4,3	690	12,0	0,2800	160	Y	16,5	2,0	2500	0,058	95	
		25	4,9	680	13,0				19,0	1,8				
		15	4,9	680	13,0				19,0	1,8				
SPH	132 L8	100	3,6	715	11,0				12,0	3,2				
		60	4,5	705	12,5				15,0	2,5				
		40	5,3	695	13,5	0,2780	190	Y	17,5	2,1	2500	0,068	105	
		25	6,0	680	15,5				19,5	1,8				
		15	6,2	675	16,0				20,0	1,8				
SPH	160 M8	100	5,3	730	16,5				16,5	3,5				
		60	6,0	725	17,0				19,0	3,0				
		40	7,2	720	19,0	0,1590	205	Y	22,0	2,5	2400	0,163	145	
		25	8,0	715	20,5				25,0	2,2				
		15	8,5	715	21,5				26,0	2,1				
SPH	160 L8	100	7,0	730	22,0				19,5	3,6				
		60	8,5	730	24,0				24,0	2,9				
		40	9,5	725	26,0	0,1300	225	Y	26,0	2,6	2400	0,190	170	
		25	11,5	720	31,0				32,0	2,1				
		15	12,5	715	34,0				35,0	1,9				
SPH	180 M8	100	11,0	725	29,0				31,0	3,3				
		60	13,0	720	31,5				37,0	2,7				
		40	15,5	715	36,0	0,0823	220	Y	44,0	2,3	2200	0,308	225	
		25	17,5	710	39,5				49,0	2,0				
		15	20,0	705	45,0				56,0	1,8				
SPH	180 L8	100	14,0	730	35,5				38,0	3,8				
		60	17,0	725	39,5				46,0	3,1				
		40	20,0	720	40,5	0,0611	230	Y	54,0	2,6	2200	0,365	260	
		25	22,5	715	50,5				61,0	2,3				
		15	26,0	710	57,5				70,0	2,0				
SPH	200 M8	100	18,5	730	45,0				60,0	3,4				
		60	21,0	730	48,5				68,0	3,0				
		40	25,0	725	55,0	0,0257	190	Y	81,0	2,5	1875	0,568	330	
		25	28,0	720	60,5				91,0	2,2				
		15	33,0	715	71,0				108,0	1,9				
SPH	225 M8	100	22,0	735	50,5				68,0	3,4				
		60	25,0	730	54,5				77,0	3,0				
		40	32,0	725	66,5	0,0218	200	Y	99,0	2,3	1875	0,990	425	
		25	36,0	725	74,0				111,0	2,1				
		15	42,0	720	85,0				130,0	1,8				
S10H	250 M8	100	30,0	735	62,0				90,0	2,9				
		60	35,0	730	71,0				105,0	2,5				
		40	42,0	725	84,0	0,0488	210	Δ	126,0	2,1	1875	1,780	600	
		25	48,0	725	97,0				145,0	1,8				
		15	48,0	725	97,0				145,0	1,8				
S10H	250 L8	100	37,0	738	86,5				103,0	3,5				
		60	43,0	736	96,0				118,0	3,0				
		40	52,0	734	112,0	0,0380	225	Δ	143,0	2,5	1875	1,950	665	
		25	60,0	732	126,0				165,0	2,2				
		15	68,0	730	140,0				186,0	1,9				
S10H	280 M8	100	45,0	740	101,0				110,0	3,9				
		60	52,0	740	113,0				128,0	3,4				
		40	63,0	737	133,0	0,0348	250	Δ	158,0	2,8	1875	3,100	850	
		25	68,0	735	142,0				170,0	2,6				
		15	77,0	735	162,0				190,0	2,3				
S10H	280 L8	100	55,0	740	121,0				126,0	3,5				
		60	67,0	740	143,0				153,0	2,9				
		40	80,0	737	166,0	0,0340	270	Δ	183,0	2,4	1875	3,620	950	
		25	90,0	735	184,0				206,0	2,1				
		15	105	730	216,0				240,0	1,8				

Drehstrommotoren mit Schleifringläufer für Aussetzbetrieb

Reihen SPH und S10H, progressive Leistungszuordnung
mit Oberflächenkühlung, Betriebsart S3
Wärmeklasse F, Schutzart IP 54/IP 55

Motorauswahldaten											Bemessungspunkt 400 V, 50 Hz		
Typ		S3- %	P kW	n min ⁻¹	I 400 V A	R Ω	Läufer U V		I A	M _K /M _B -	n _{max} min ⁻¹	J kgm ²	m kg
Synchrondrehzahl 600 min ⁻¹ – 10-polige Ausführung													
SPH	225 M10	100	16,0	590	48,0				50,0	3,2			
		60	21,0	585	56,0				65,0	2,4			
		40	24,0	580	61,0	0,0324	200	Y	74,0	2,1	1500	0,937	425
		25	28,0	580	68,0				87,0	1,8			
		15	28,0	580	68,0				87,0	1,8			
S10H	250 M10	100	20,0	590	65,0				57,0	3,4			
		60	26,0	585	72,5				75,0	2,6			
		40	30,0	585	79,0	0,0831	220	Δ	86,0	2,3	1500	1,520	580
		25	34,0	580	86,5				98,0	2,0			
		15	34,0	580	86,5				98,0	2,0			
S10H	250 MX10	100	24,0	590	86,5				68,0	3,7			
		60	30,0	585	93,0				85,0	3,0			
		40	36,0	585	103,0	0,0584	220	Δ	101,0	2,5	1500	1,730	600
		25	43,0	580	114,0				121,0	2,1			
		15	43,0	580	114,0				121,0	2,1			
S10H	280 M10	100	33,0	590	90,0				89,0	3,0			
		60	40,0	590	100,0				108,0	2,5			
		40	45,0	585	109,0	0,0462	230	Δ	121,0	2,2	1500	3,100	850
		25	52,0	585	125,0				140,0	1,9			
		15	52,0	585	125,0				140,0	1,9			
S10H	280 L10	100	43,0	590	103,0				102,0	2,5			
		60	50,0	585	116,0				119,0	2,2			
		40	55,0	585	127,0	0,0523	260	Δ	131,0	2,0	1500	3,620	950
		25	60,0	585	137,0				143,0	1,8			
		15	60,0	585	137,0				143,0	1,8			

Lagerung

Bauteile Schleifkontaktsystem

Baureihen SPER, S11R

Lagerung

Typ SPER S11R	Polzahl	D-Seite (DS)				N-Seite (NS)		Art der Schmierung	Bild	
		Wälzlager	V-Ring	Wellfeder	Tellerfeder	Wälzlager	V-Ring		D-Seite	N-Seite
132	M4-8	6308 2Z C3	-	90	-	6308 2Z C3	-	Dauerschmierung	2/1	2/13
132	MX4-8	6308 2Z C3	-	90	-	6308 2Z C3	-		2/1	2/13
160	M4-8	6310 2Z C3	-	110	-	6309 2Z C3	-		2/1	2/13
160	L4-8	6310 2Z C3	-	110	-	6309 2Z C3	-		2/1	2/13
180	L4-8	6310 C3	50 A	110	-	6310 C3	50 A		2/3	2/4
200	L4-8	6312 C3	60 A	-	130	6312 C3	60 A		2/3	2/4
200	M4-8	6312 C3	60 A	-	130	6312 C3	60 A		2/3	2/4
225	M4-8	6313 C3	65 A	-	140	6312 C3	60 A		2/3	2/4
225	MX6, 8	6313 C3	65 A	-	140	6312 C3	60 A		2/3	2/4
250	M, MX4	6315 C3	75 A	-	160	6313 C3	65 A		2/3	2/4
250	MX6, 8	NU 316 EJ	80 A	-	-	6314 C3	70 A	2/5	2/4	
280	S, M4	NU 316 EJ	80 A	-	-	6314 C3	70 A	2/5	2/4	
280	M6, 8	NU 316 EJ	80 A	-	-	6314 C3	70 A	2/5	2/4	
315	S4-8	NU 317 EJ	85 A	-	-	6316 C3	80 A	2/5	2/4	
315	M4-8	NU 317 EJ	85 A	-	-	6316 C3	80 A	2/5	2/4	
315	MX, MY4-8	NU 320 EJ	100 ¹⁾	-	-	6317 C3 ²⁾	85 A	Nachschmier- einrichtung	2/22	2/23
315	LX4-8, LY4	NU 320 EJ	100 ¹⁾	-	-	6317 C3 ²⁾	85 A	2/22	2/23	

¹⁾ Gamma-Ring RB 100

²⁾ für senkrechte Bauformen Q 317

Bauteile Schleifkontaktsystem

Typ SPER/ S11R	Polzahl	Taschenbürstenhalter Bestell-Nr.	Kohlebürsten Bestell-Nr.	Schleifringkörper Bestell-Nr.
132	M4, 6, 8	TIKZ2f 10 x 8-16-42-21	10 x 8 x 25/RC53 25938 01	E 100 x 55-310 12294 01
132	MX4, 6, 8	13867 01	10 x 8 x 25/RC53 25938 01	E 100 x 55-310 12294 01
160	M4, L4	TIKZ2f 10 x 8-16-42-21	10 x 8 x 25/C40 01500 01	E 120 x 65-310 12280 01
160	M6, 8	13867 01	10 x 8 x 25/RC53 01503 01	E 120 x 65-310 12280 01
160	L6,8		10 x 8 x 25/RC53 01503 01	E 120 x 65-310 12280 01
180	L4	TIKZ2f 16 x 8-16-45-21	16 x 8 x 25/RC90 24743 01	E 140 x 80-316 12293 01
180	L6, 8	12271 01	16 x 8 x 25/RC53 01501 01	E 140 x 80-316 12293 01
200	L4, 6, 8	TIKZ2f 16 x 12,5-20-52-23,5	16 x 12,5 x 32/RC53 01502 01	E 160 x 90-316 12302 01
200	LX4	14487 01	16 x 12,5 x 32/RC53 01502 01	E 160 x 90-316 12302 01
225	M4	TIKZ2f 16 x 12,5-20-52-23,5	16 x 12,5 x 32/RC90 24745 01	E 160 x 90-316 12302 01
225	M6, 8	14487 01	16 x 12,5 x 32/RC53 01502 01	E 160 x 90-316 12302 01
225	MX6, 8		16 x 12,5 x 32/RC53 01502 01	E 160 x 90-316 12302 01
250	M4, 6, 8	TIKZ2f 25 x 12,5-20-56,5-23,5	25 x 12,5 x 32/C40 50281 01	E 160 x 95-316 12286 01
250	MX4	12275 01	25 x 12,5 x 32/C40 50281 01	E 160 x 95-316 12286 01
250	MX6, 8		25 x 12,5 x 32/C40 50283 01	E 180 x 105-316 16527 01
280	S4, 6	TIKZ2f 25 x 12,5-20-56,5-23,5	25 x 12,5 x 32/B14Z1 63010 01	E 180 x 105-316 16527 01
280	M4, 6	12275 01	25 x 12,5 x 32/B14Z1 63010 01	E 180 x 105-316 16527 01
280	S, M8		25 x 12,5 x 32/C40 50283 01	E 180 x 105-316 16527 01
315	S4, 6	TIKZ2f 32 x 12,5-20-60-23,5	32 x 12,5 x 32/ B14Z1 61869 01	E 200 x 120-316 16529 01
315	M4, 6	12276 01	32 x 12,5 x 32/ B14Z1 61869 01	E 200 x 120-316 16529 01
315	S, M8		32 x 12,5 x 32/C40 50285 01	E 200 x 120-316 16529 01
315	MX, MY4-8	DKS 3216	32 x 16 x 40/C40 57393 01	SK 111 EW-N 9012 57793 01
315	LX4-8, LY4	57402 01	32 x 16 x 40/C40 57393 01	SK 111 EW-N 9012 57793 01

Baureihen SPEH, S11H

Lagerung

Typ SPEH S11H	Polzahl	Wälzlager	D-Seite (DS)			N-Seite (NS)		Art der Schmierung	Bild	
			V-Ring	Wellfeder	Tellerfeder	Wälzlager	V-Ring		D-Seite	N-Seite
132	M4-8	6308 2Z C3	-	90	-	6308 2Z C3	-	Dauerschmierung	2/1	2/13
132	MX4-8	6308 2Z C3	-	90	-	6308 2Z C3	-		2/1	2/13
160	M4-8	6310 2Z C3	-	110	-	6309 2Z C3	-		2/1	2/13
160	L4-8	6310 2Z C3	-	110	-	6309 2Z C3	-		2/1	2/13
180	L4-8	6310 C3	50 A	110	-	6310 C3	50 A		2/3	2/4
200	L4-8	6312 C3	60 A	-	130	6312 C3	60 A		2/3	2/4
200	LX4	6312 C3	60 A	-	130	6312 C3	60 A		2/3	2/4
225	M4-8	6313 C3	65 A	-	140	6312 C3	60 A		2/3	2/4
225	MX6, 8	6313 C3	65 A	-	140	6312 C3	60 A		2/3	2/4
250	M, MX4	6315 C3	75 A	-	160	6313 C3	65 A		2/3	2/4
250	MX6, 8	NU 316 EJ	80 A	-	-	6314 C3	70 A	2/5	2/4	
280	S, M4	NU 317 EJ	85 A	-	-	6314 C3	70 A	2/5	2/4	
280	M6, 8	NU 317 EJ	85 A	-	-	6314 C3	70 A	2/5	2/4	
315	S4-8	NU 319 EJ	95 A	-	-	6316 C3	80 A	2/5	2/4	
315	M4-8	NU 319 EJ	95 A	-	-	6316 C3	80 A	2/5	2/4	
315	MX, MY4-8	NU 320 EJ	100 ¹⁾	-	-	6317 C3 ²⁾	85 A	Nachschmier- einrichtung	1/22	1/23
315	LX4-8, LY4	NU 320 EJ	100 ¹⁾	-	-	6317 C3 ²⁾	85 A	Nachschmier- einrichtung	1/22	1/23

¹⁾ Gamma-Ring RB 100

²⁾ für senkrechte Bauformen Q 317

Bauteile Schleifkontaktsystem

Typ SPEH/ S11H	Polzahl	Taschenbürstenhalter Bestell-Nr.	Kohlebürsten Bestell-Nr.	Schleifringkörper Bestell-Nr.
132	M4, 6, 8	TIKZ2f 10 x 8-16-42-21	10 x 8 x 25/RC53 25938 01	E 100 x 55-310 12294 01
132	MX4, 6, 8	13867 01	10 x 8 x 25/RC53 25938 01	E 100 x 55-310 12294 01
160	M4, L4	TIKZ2f 10 x 8-16-42-21	10 x 8 x 25/C40 01500 01	E 120 x 65-310 12280 01
160	M6, 8	13867 01	10 x 8 x 25/RC53 01503 01	E 120 x 65-310 12280 01
160	L6,8		10 x 8 x 25/RC53 01503 01	E 120 x 65-310 12280 01
180	L4	TIKZ2f 16 x 8-16-45-21	16 x 8 x 25/RC90 24743 01	E 140 x 80-316 12293 01
180	L6, 8	12271 01	16 x 8 x 25/C40 57461 01	E 140 x 80-316 X6 20492 01
200	L4, 6, 8	TIKZ2f 16 x 12,5-20-52-23,5	16 x 12,5 x 32/RC53 01502 01	E 160 x 90-316 12302 01
200	LX4	14487 01	16 x 12,5 x 32/RC53 01502 01	E 160 x 90-316 12302 01
225	M4	TIKZ2f 16 x 12,5-20-52-23,5	16 x 12,5 x 32/RC90 24745 01	E 160 x 90-316 12302 01
225	M6, 8	14487 01	16 x 12,5 x 32/RC53 01502 01	E 160 x 90-316 12302 01
225	MX6, 8		16 x 12,5 x 32/RC53 01502 01	E 160 x 90-316 12302 01
250	M4, 6, 8	TIKZ2f 25 x 12,5-20-56,5-23,5	25 x 12,5 x 32/C40 50281 01	E 160 x 95-316 12286 01
250	MX4	12275 01	25 x 12,5 x 32/C40 50281 01	E 160 x 95-316 12286 01
250	MX6, 8		25 x 12,5 x 32/C40 50283 01	E 180 x 105-316 16527 01
280	S4, 6	TIKZ2f 32 x 12,5-20-60-23,5	32 x 12,5 x 32/C40 57441 01	E 180 x 105-316 16527 01
280	M4, 6	12276 01	32 x 12,5 x 32/C40 57441 01	E 180 x 105-316 16527 01
280	S, M8	TIKZ2f 25 x 12,5-20-56,5-23,5 12275 01	25 x 12,5 x 32/C40 50283 01	E 180 x 105-316 16527 01
315	S4, 6	TIKZ2f 32 x 12,5-20-60-23,5	32 x 12,5 x 32/B14Z1 61869 01	E 200 x 120-316 16529 01
315	M4, 6	12276 01	32 x 12,5 x 32/B14Z1 61869 01	E 200 x 120-316 16529 01
315	S, M8		32 x 12,5 x 32/C40 50285 01	E 200 x 120-316 16529 01
315	MX, MY4-8	DKS 3216	32 x 16 x 40/C40 57393 01	SK 111 EW-N 9012 57793 01
315	LX4-8, LY4	57402 01	32 x 16 x 40/C40 57393 01	SK 111 EW-N 9012 57793 01

Baureihen SPR, SPH

Lagerung

Typ SPR SPH	Wälzlager	D-Seite (DS)			N-Seite (NS)		Bild		Art der Schmierung
		V-Ring	Wellfeder	Tellerfeder	Wälzlager	V-Ring	D-Seite	N-Seite	
132	6308 2Z C3	-	90	-	6308 2Z C3	-	2/1	2/13	Dauerschmierung
160	6310 2Z C3	-	110	-	6309 2Z C3	-	2/1	2/13	
180	6312 C3	60 A	-	130	6310 C3	50 A	2/3	2/4	
200	6313 C3	65 A	-	140	6312 C3	60 A	2/3	2/4	
225	6314 C3	70 A	-	150	6313 C3	65 A	2/3	2/4	
250	NU 316 EJ	80 A	-	-	6314 C3	70 A	2/5	2/4	
280	NU 317 EJ	85 A	-	-	6316 C3	80 A	2/5	2/4	

Bauteile Schleifkontaktsystem

Typ SPR	Polzahl	Taschenbürstenhalter Bestell-Nr.	Kohlebürsten Bestell-Nr.	Schleifringkörper Bestell-Nr.
132	alle	TIKZ2f 10 x 8-16-42-21 13867 01	10 x 8 x 25/RC53 25938 01	E 100 x 55-310 12294 01
160	alle	TIKZ2f 10 x 8-16-42-21 13867 01	10 x 8 x 25/C40 01500 01	E 120 x 65-310 12280 01
180	alle	TIKZ2f 16 x 8-16-45-21 12271 01	16 x 8 x 25/RC90 24743 01	E 140 x 80-316 12293 01
200	alle	TIKZ2f 16 x 12,5-20-52-23,5 14487 01	16 x 12,5 x 32/RC90 24745 01	E 160 x 90-316 12302 01
225	alle	TIKZ2f 16 x 12,5-20-52-23,5 14487 01	16 x 12,5 x 32/RC90 24745 01	E 160 x 95-316 12286 01
250	alle	TIKZ2f 20 x 12,5-20-54-23,5 12273 01	20 x 12,5 x 32/RC90 24747 01	E 180 x 105-316 16527 01
280	alle	TIKZ2f 25 x 12,5-20-56,5-23,5 12275 01	25 x 12,5 x 32/RC90 24749 01	E 200 x 120-316 16529 01
Typ SPH				
132	alle	TIKZ2f 10 x 8-16-42-21 13867 01	10 x 8 x 25/RC53 25938 01	E 100 x 55-310 12294 01
160	alle	TIKZ2f 10 x 8-16-42-21 13867 01	10 x 8 x 25/C40 01500 01	E 120 x 65-310 12280 01
180	M, L4	TIKZ2f 16 x 8-16-45-21	16 x 8 x 25/RC90 24743 01	E 140 x 80-316 12293 01
180	M, L 6,8	12271 01	16 x 8 x 25/C40 57461 01	E 140 x 80-316 X6 20492 01
200	alle	TIKZ2f 16 x 12,5-20-52-23,5 14487 01	16 x 12,5 x 32/RC90 24745 01	E 160 x 90-316 12302 01
225	alle	TIKZ2f 16 x 12,5-20-52-23,5 14487 01	16 x 12,5 x 32/RC90 24745 01	E 160 x 95-316 12286 01
250	alle	TIKZ2f 20 x 12,5-20-54-23,5 12273 01	20 x 12,5 x 32/RC90 24747 01	E 180 x 105-316 16527 01
280	alle	TIKZ2f 25 x 12,5-20-56,5-23,5 12275 01	25 x 12,5 x 32/RC90 24749 01	E 200 x 120-316 16529 01

Bildteil

Bild 2/1	Bild 2/2	Bild 2/3	Bild 2/4
Bild 2/5	Bild 2/6	Bild 2/7	Bild 2/8
Bild 2/9	Bild 2/10	Bild 2/11	Bild 2/12
Bild 2/13	Bild 2/14	Bild 2/15	Bild 2/16

Bildteil

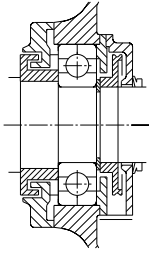
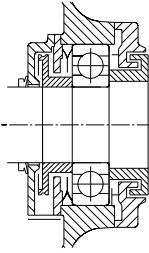
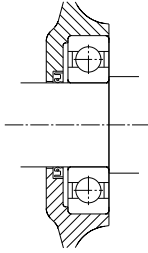
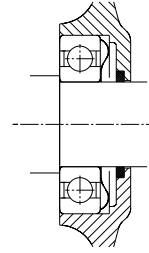
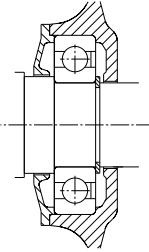
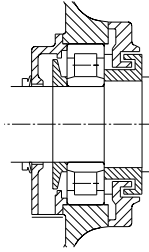
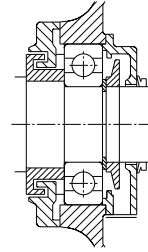
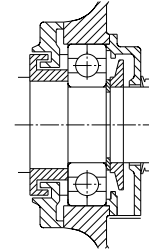
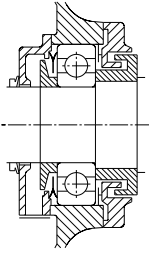
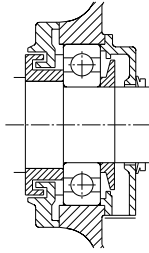
			
Bild 2/17	Bild 2/18	Bild 2/19	Bild 2/20
			
Bild 2/21	Bild 2/22	Bild 2/23	Bild 2/24
			
Bild 2/25	Bild 2/26		

Anschlusskästen

Standardausführung, Kabelvergussstutzen

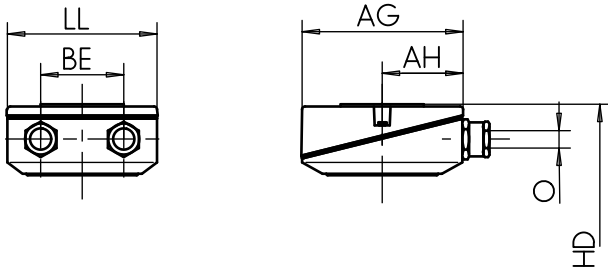

Standanschlusskasten für Kabelverschraubungen

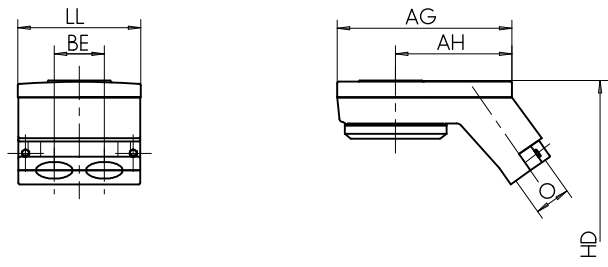

Standanschlusskasten für Kabelvergussstutzen

Typ	Werkstoff	Zwischenflansch	Abmessungen				Gewinde Kabeleinführung	max. Kabeldurchmesser	Klemmsoclel	Anzahl der Klemmen	Gewinde Anschlussbolzen	Gewinde Schutzleiter	Bild
			AG x	LL z	AH -	BE -							
Standardausführung													
25 A	Alu	-	156	145	-	-	M32 x 1,5	Ø 21 mm	SB 5	6	M5	M6	01
25 A SS	GG-15	-	143	134	-	-	M32 x 1,5	Ø 21 mm	SB 5	6	M5	M6	01
63/25 A	Alu	-	193	167	-	-	M40 x 1,5	Ø 28 mm	SB 5	6	M5	M6	01
63 A	Alu	-	193	167	-	-	M40 x 1,5	Ø 28 mm	SB 6	6	M6	M6	01
63 A	GG-15	-	174	162	-	-	M40 x 1,5	Ø 28 mm	SB 6	6	M6	M6	01
63 A	Alu	-	193	167	-	-	M50 x 1,5	Ø 35 mm	SB 6	6	M6	M6	01
63 A	GG-15	-	174	162	-	-	M50 x 1,5	Ø 35 mm	SB 6	6	M6	M6	01
100 A	GG-15	-	213	207	-	-	M50 x 1,5	Ø 35 mm	SB 8	6	M8	M8	01
200/100 A	GG-15	-	282	242	-	-	M63 x 1,5	Ø 45 mm	SB 8	6	M8	M8	01
200 A	GG-15	-	282	242	-	-	M63 x 1,5	Ø 45 mm	SB 10	6	M10	M10	01
400 A	GG-15	-	315	294	-	-	M63 x 1,5	Ø 45 mm	SB 12	6	M12	M10	02
400 B	GG-15	-	415	340	265	-	M63 x 1,5	Ø 45 mm	KM 12	6	M12	LK	03
400 B	GG-15	-	415	340	265	-	M72 x 2	Ø 56,5 mm	KM 12	6	M12	LK	03
Kabelvergussstutzen													
VGK 400 A	GG-15	-	422	296	-	-	Ø 95	Ø 95 mm	SB 12	6	M12	M10	04

Standardausführung, Kabelvergussstutzen



Bild 01



Bild 02

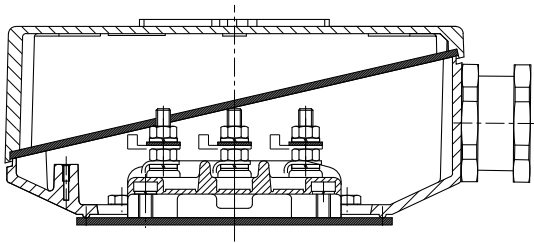

Bild 04

Bild 03

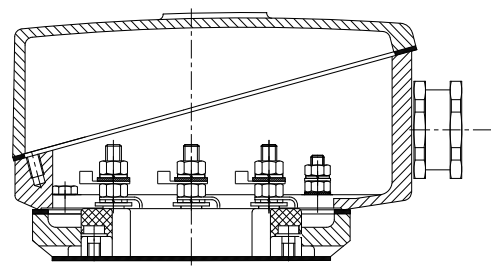
Maße

Drehstrommotoren mit Schleifringläufer, Grundausführung SPER 132–250/S11R 250–315 M

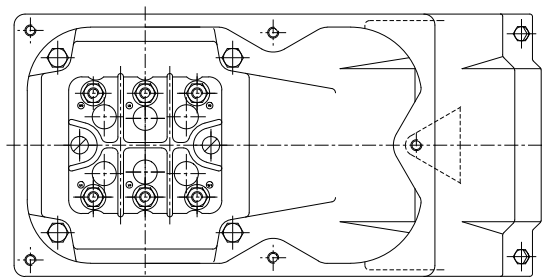
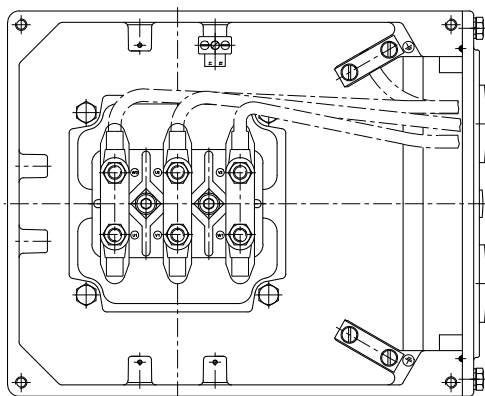
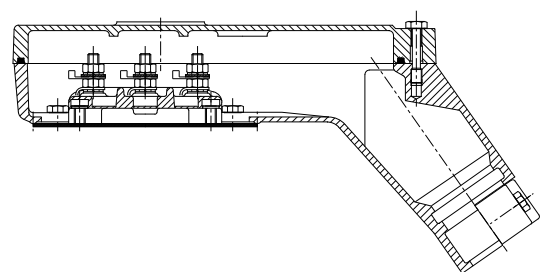
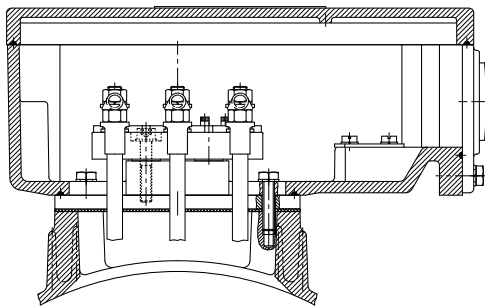
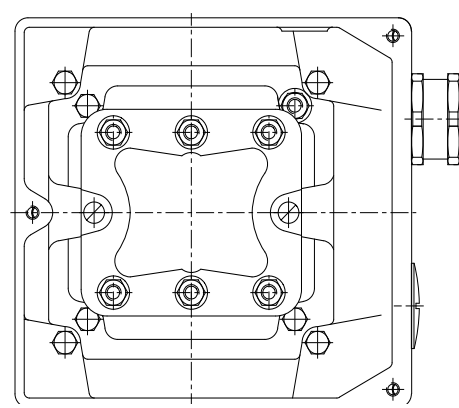
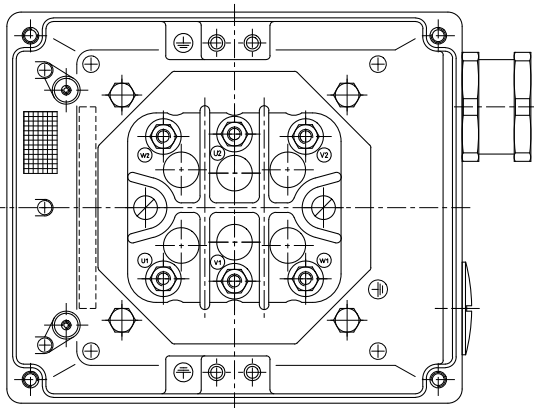
mit Oberflächenkühlung, Kühlart IC 411, Schutzart IP 54/IP 55

Bauform IM B3 [IM 1001], IM 1002

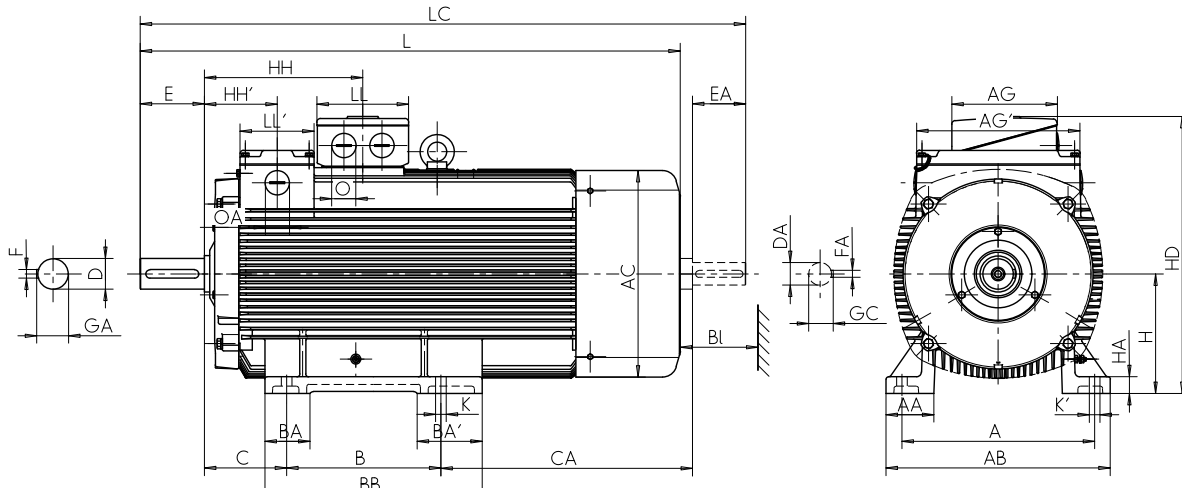

Bauform IM B35 [IM 2001], IM 2002

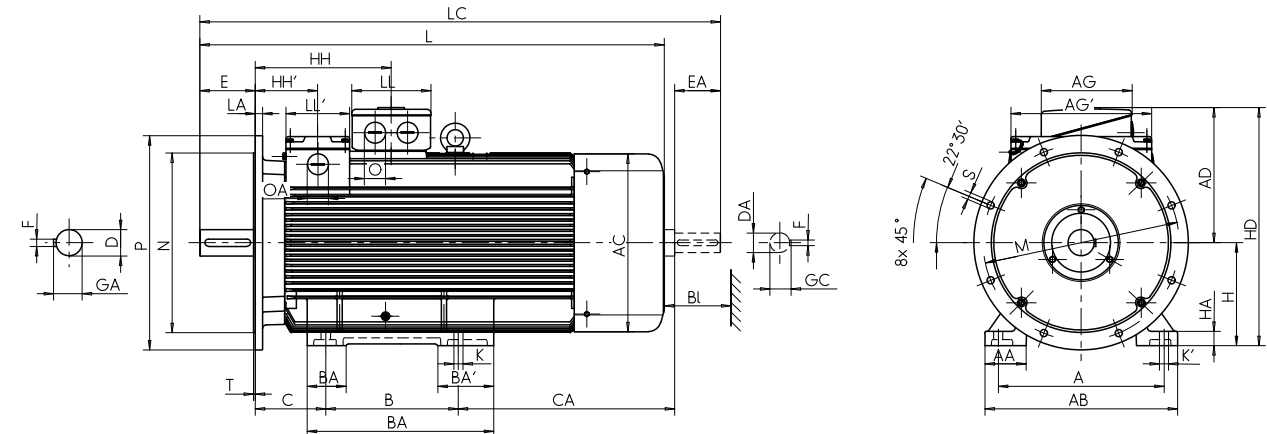

Typ	IM B5	IM B35	A	AA	AB	AC	B	BA	BA'	BB	C	CA	D	DA	E	EA	F	FA	
	b	n	f	g	a	m	m1	e	w1	w2	d	d1	Zentrierbohrung DIN 332-DS	l	l1	u	u1		
SPER 132 M	A300	A300	216	50	256	258	178	55	55	218	89	300	38	38	M12	80	80	10	10
SPER 132 MX	A300	A300	216	50	256	258	178	55	55	218	89	300	38	38	M12	80	80	10	10
SPER 160 M	A350	A350	254	55	296	313	210	60	60	257	108	339	42	42	M16	110	110	12	12
SPER 160 L	A350	A350	254	55	296	313	254	60	60	301	108	305	42	42	M16	110	110	12	12
SPER 180 L	A350	A350	279	62	328	351	279	65	65	326	121	315	48	48	M16	110	110	14	14
SPER 200 L	A400	A400	318	70	372	390	305	70	70	360	133	393	55	55	M20	110	110	16	16
SPER 200 LX	A400	A400	318	70	372	390	305	70	70	360	133	393	55	55	M20	110	110	16	16
SPER 225 M	A450	A450	356	75	413	390	311	75	75	368	149	371	60	55	M20	140	110	18	16
SPER 225 MX	A450	A450	356	75	413	390	311	75	75	368	149	371	60	55	M20	140	110	18	16
SPER 250 M	A550	A550	406	84	471	440	349	84	84	412	168	426	65	60	M20	140	140	18	18
S11R 250 MX6	A550	A550	406	84	469	490	349	84	84	412	168	524	65	60	M20	140	140	18	18
S11R 280 S4	A550	A550	457	94	522	490	368	96	96	431	190	483	75	60	M20	140	140	20	18
S11R 280 S8	A550	A550	457	94	522	490	368	96	138	482	190	563	75	60	M20	140	140	20	18
S11R 280 M4	A550	A550	457	94	522	490	419	96	138	482	190	512	75	60	M20	140	140	20	18
S11R 280 M6	A550	A550	457	94	522	490	419	96	138	482	190	512	75	60	M20	140	140	20	18
S11R 315 S4	A660	A660	508	126	590	550	406	120	120	520	216	583	80	65	M20	170	140	22	18
S11R 315 S6	A660	A660	508	126	590	550	406	120	172	572	216	663	80	65	M20	170	140	22	18
S11R 315 M	A660	A660	508	126	590	550	457	120	172	572	216	612	80	65	M20	170	140	22	18

Drehstrommotoren mit Schleifringläufer, Grundausführung SPER 132–250/S11R 250–315 M

mit Oberflächenkühlung, Kühlart IC 411, Schutzart IP 54/IP 55

Bauform IM B5 [IM 3001], IM 3002; IM V1 [IM 3011], IM 2012

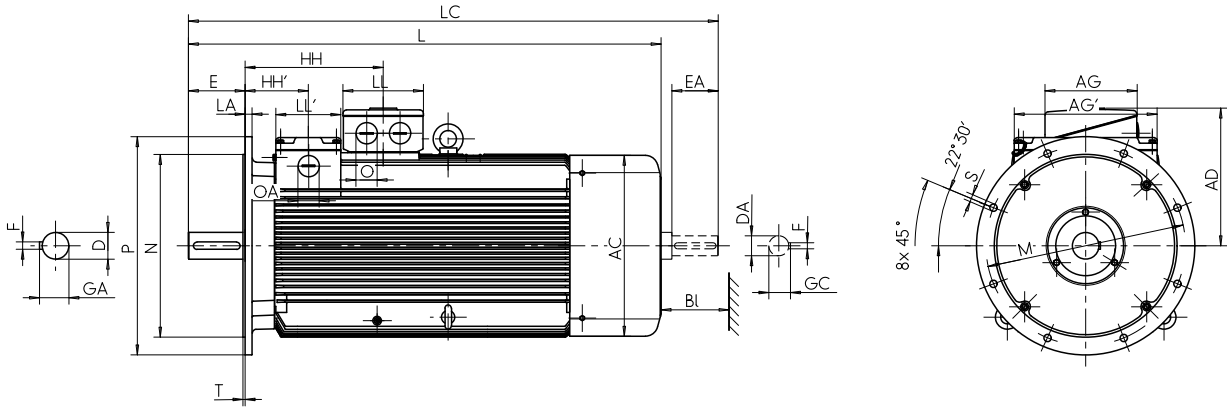

Typ	GA	GC	H	HA	HD	K	K'	L	LC	LD	LD	LE	Anschlusskasten			Schleifringraum			-	-	-	
	t	t1	h	c	p (B3)	s	s'	k	k1	A (IM B3)	A (IM B5)	A1	Typ	x'	z'	r	AG'	LL'	OA	Bl	Lochbild	NS möglich
SPER 132 M	41	41	132	16	331	12	12	643	727	242	242	-	25 A	156	145	M32 x 1,5	221	120	M32 x 1,5	35	4	nein
SPER 132 MX	41	41	132	16	331	12	12	643	727	242	242	-	25 A	156	145	M32 x 1,5	221	120	M32 x 1,5	35	4	nein
SPER 160 M	45	45	160	18	402	15	15	762	877	292	292	-	63 A	193	167	M40 x 1,5	272	140	M40 x 1,5	35	4	nein
SPER 160 L	45	45	160	18	402	15	15	762	877	292	292	-	63 A	193	167	M40 x 1,5	272	140	M40 x 1,5	35	4	nein
SPER 180 L	52	52	180	20	441	15	15	819	935	301	301	-	63 A	193	167	M40 x 1,5	292	140	M40 x 1,5	35	4	nein
SPER 200 L	59	59	200	22	500	19	19	927	1051	331	331	-	100 A	213	207	M50 x 1,5	310	145	M50 x 1,5	40	4	nein
SPER 200 LX	59	59	200	22	500	19	19	927	1051	331	331	-	100 A	213	207	M50 x 1,5	310	145	M50 x 1,5	40	4	nein
SPER 225 M	64	59	225	25	525	19	19	957	1081	331	331	-	100 A	213	207	M50 x 1,5	310	145	M50 x 1,5	40	8	ja
SPER 225 MX	64	59	225	25	525	19	19	957	1081	331	331	-	100 A	213	207	M50 x 1,5	310	145	M50 x 1,5	40	8	ja
SPER 250 M	69	64	250	28	576	24	24	1072	1224	342	342	-	100 A	213	207	M50 x 1,5	382	195	M50 x 1,5	45	8	ja
S11R 250 MX6	69	64	250	28	636	24	24	1166	1321	411	411	-	200 A	282	242	M63 x 1,5	382	195	M63 x 1,5	50	8	ja
S11R 280 S4	80	64	280	40	696	24	30	1166	1321	411	411	-	200 A	282	242	M63 x 1,5	382	195	M63 x 1,5	50	8	ja
S11R 280 S8	80	64	280	40	696	24	30	1246	1401	411	411	-	200 A	282	242	M63 x 1,5	382	195	M63 x 1,5	50	8	ja
S11R 280 M4	80	64	280	40	696	24	30	1246	1401	411	411	-	200 A	282	242	M63 x 1,5	382	195	M63 x 1,5	50	8	ja
S11R 280 M6	80	64	280	40	696	24	30	1246	1401	411	411	-	200 A	282	242	M63 x 1,5	382	195	M63 x 1,5	50	8	ja
S11R 315 S4	85	69	315	44	731	28	35	1348	1515	416	416	-	200 A	282	242	M63 x 1,5	430	195	M63 x 1,5	55	8	ja
S11R 315 S6	85	69	315	44	731	28	35	1428	1595	416	416	-	200 A	282	242	M63 x 1,5	430	195	M63 x 1,5	55	8	ja
S11R 315 M	85	69	315	44	731	28	35	1428	1595	416	416	-	200 A	282	242	M63 x 1,5	430	195	M63 x 1,5	55	8	ja

**Drehstrommotoren mit Schleifringläufer,
Grundausführung S11R 315 MX, MY, LX, LY**

mit Oberflächenkühlung, Kühlart IC 411, Schutzart IP 55

Bauform IM B3 [IM 1001], IM 1002

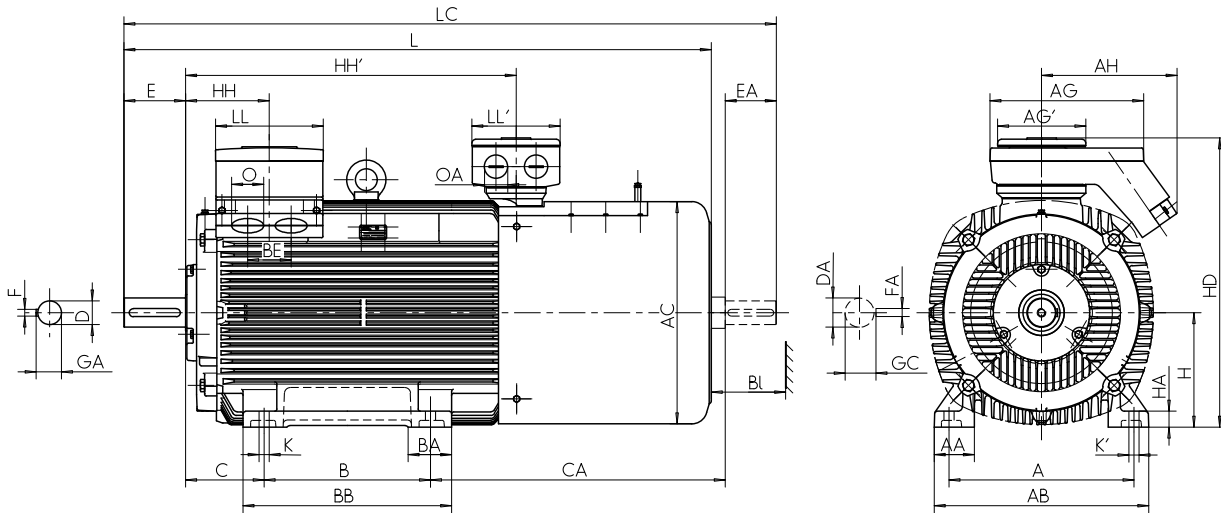

Bauform IM B35 [IM 2001], IM 2002

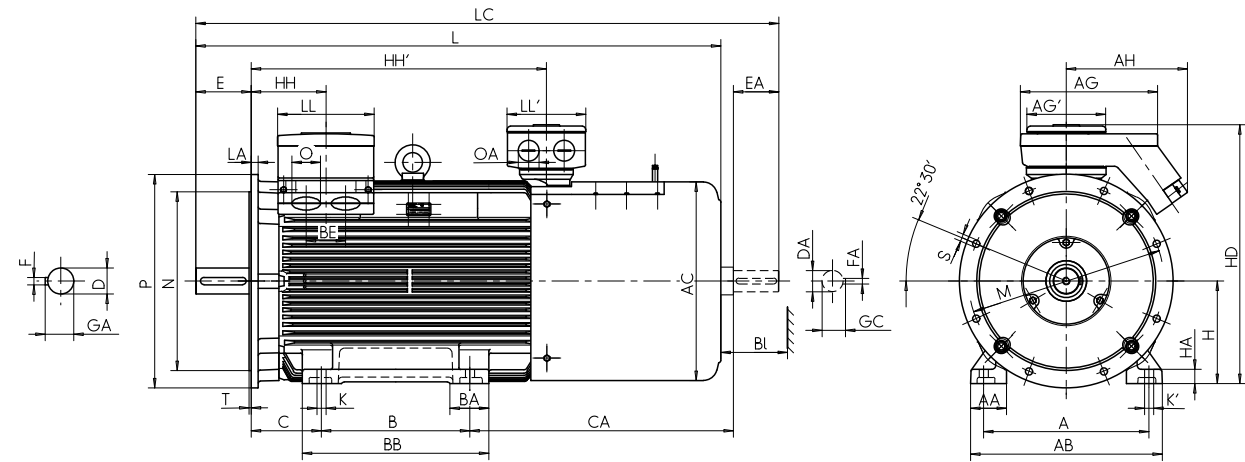

	-	-	A	AA	AB	AC	B	BA	BA'	BB	C	CA	D	DA	-	E	EA	F	FA
	IM B5	IM B35	b	n	f	g	a	m	m1	e	w1	w2	d	d1	Zentrierbohrung DIN 332-DS	l	l1	u	u1
S11R 315 MX4	A660	A660	508	110	590	610	457	120	120	573	216	810	80	65	M20	170	140	22	18
S11R 315 MY4	A660	A660	508	110	590	610	457	120	120	573	216	810	80	65	M20	170	140	22	18
S11R 315 LX4	A660	A660	508	110	590	610	508	120	120	624	216	879	80	65	M20	170	140	22	18
S11R 315 LY4	A660	A660	508	110	590	610	508	120	120	624	216	879	80	65	M20	170	140	22	18

Drehstrommotoren mit Schleifringläufer, Grundausführung S11R 315 MX, MY, LX, LY

mit Oberflächenkühlung, Kühlart IC 411, Schutzart IP 55

Bauform IM V1 [IM 3011], IM 3012

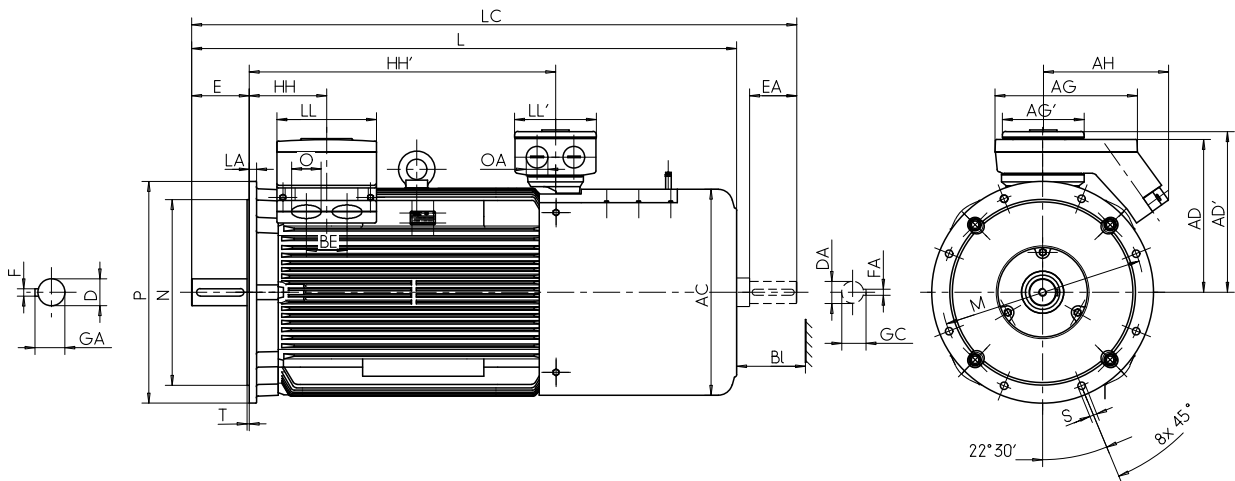

Typ	GA	GC	H	HA	HD	K	K'	L	LC	LD	LD	LE	AG	LL	O	AG'	LL'	OA	-	-	-		
	t	t1	h	c	p (B3)	s	s'	k	k1	A (IM B3)	A (IM B5)	A1	Typ	x'	z'	r	Typ	x'	z'	r	BI	Lochbild	NS möglich
	S11R 315 MX4	85	69	315	44	800	28	35	1613	1793	230	230	675	VGK400 A	422	296	Ø 95	200 A	282	242	M63 x 1,5	55	8
S11R 315 MY4	85	69	315	44	800	28	35	1613	1793	230	230	675	VGK400 A	422	296	Ø 95	200 A	282	242	M63 x 1,5	55	8	ja
S11R 315 LX4	85	69	315	44	800	28	35	1733	1913	230	230	795	VGK400 A	422	296	Ø 95	200 A	282	242	M63 x 1,5	55	8	ja
S11R 315 LY4	85	69	315	44	800	28	35	1733	1913	230	230	795	VGK400 A	422	296	Ø 95	200 A	282	242	M63 x 1,5	55	8	ja

**Drehstrommotoren mit Schleifringläufer,
Grundausführung SPER 132–160**

mit Oberflächenkühlung, Kühlart IC 411, Schutzart IP 54/IP 55

Bauform IM B34 [IM 2101], IM 2102

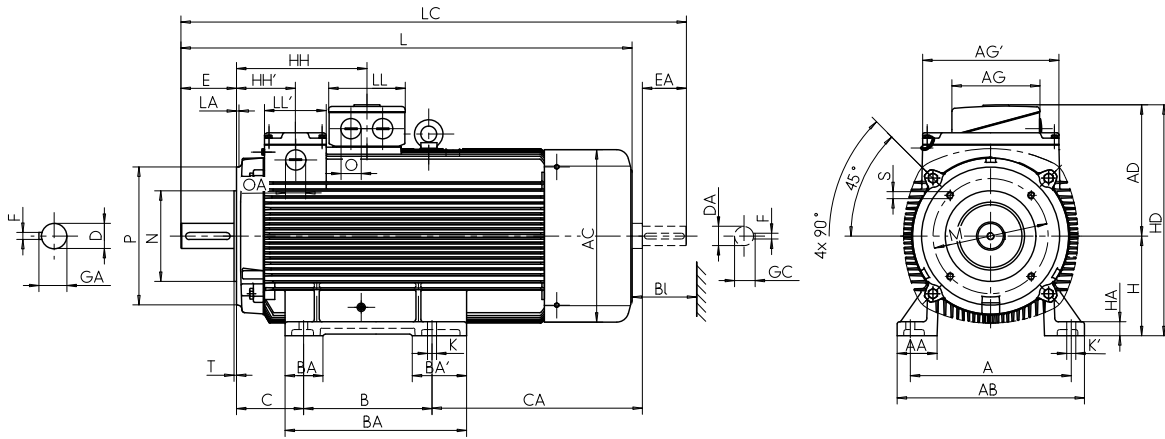

		-	-	A	AA	AB	AC	B	BA	BA'	BB	C	CA	D	DA	-	E	EA	F	FA	
IM B14K, IM B34 K	IM B14G, IM B34 G	b	n	f	g	a	m	m1	e	w1	w2	d	d1	Zentrierbohrung	l	l1	u	u1			
SPER 132 M	C200	C250	216	50	256	258	178	55	55	218	89	300	38	38	DIN 332-DS M12	80	80	10	10		
SPER 132 MX	C200	C250	216	50	256	258	178	55	55	218	89	300	38	38	DIN 332-DS M12	80	80	10	10		
SPER 160 M	C250	C300	254	55	296	313	210	60	60	257	108	339	42	42	DIN 332-DS M16	110	110	12	12		
SPER 160 L	C250	C300	254	55	296	313	254	60	60	301	108	305	42	42	DIN 332-DS M16	110	110	12	12		

Drehstrommotoren mit Schleifringläufer, Grundausführung SPER 132–160

mit Oberflächenkühlung, Kühlart IC 411, Schutzart IP 54/IP 55

Bauform IM B14 [IM 3601], IM 3602

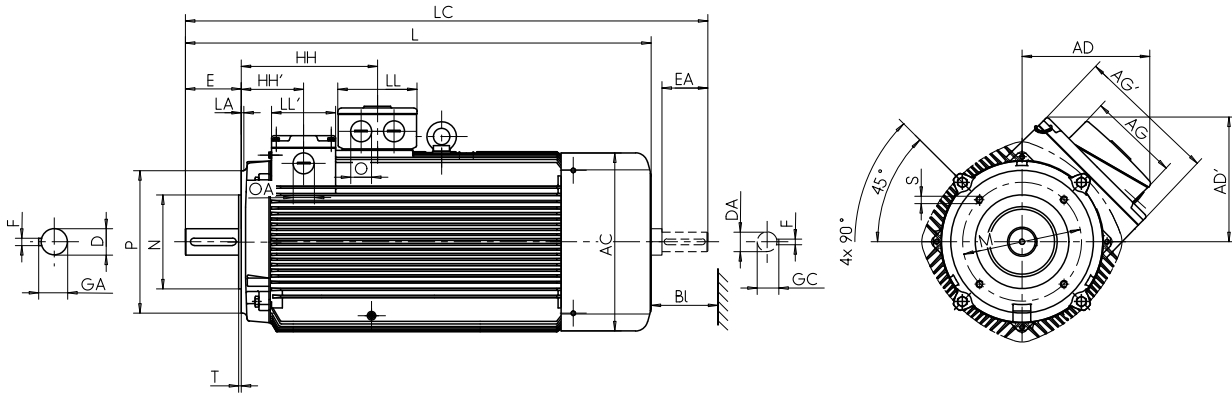

	GA	GC	H	HA	HD	K	K'	L	LC	LD	LD	LE	AG	LL	O	AG'	LL'	OA	-	-	-	
	t	t1	h	c	p (B3)	s	s'	k	k1	A (IM B14K)	A (IM B14G)	A1	Anschlusskasten			Schleifringraum			Bl	Lochbild	NS möglich	
													Typ	x	z	r	x'	z'	r'			
SPER 132 M	41	41	132	16	331	12	12	643	727	242	242	-	25 A	156	145	M32 x 1,5	221	120	M32 x 1,5	35	4	nein
SPER 132 MX	41	41	132	16	331	12	12	643	727	242	242	-	25 A	156	145	M32 x 1,5	221	120	M32 x 1,5	35	4	nein
SPER 160 M	45	45	160	18	402	15	15	762	877	292	292	-	63 A	193	167	M40 x 1,5	272	140	M40 x 1,5	35	4	nein
SPER 160 L	45	45	160	18	402	15	15	762	877	292	292	-	63 A	193	167	M40 x 1,5	272	140	M40 x 1,5	35	4	nein

**Drehstrommotoren mit Schleifringläufer,
Grundausführung SPR/S10R 132–280**

mit Oberflächenkühlung, Kühlart IC 411, Schutzart IP 54/IP 55

Bauform IM B3 [IM 1001], IM 1002

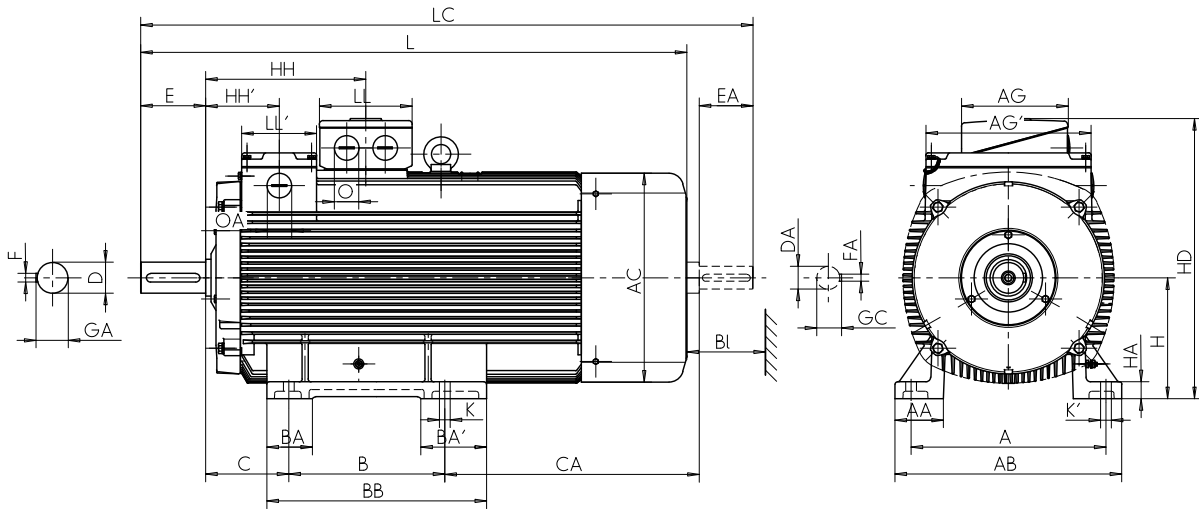

Bauform IM B3 [IM 1001], IM 1002

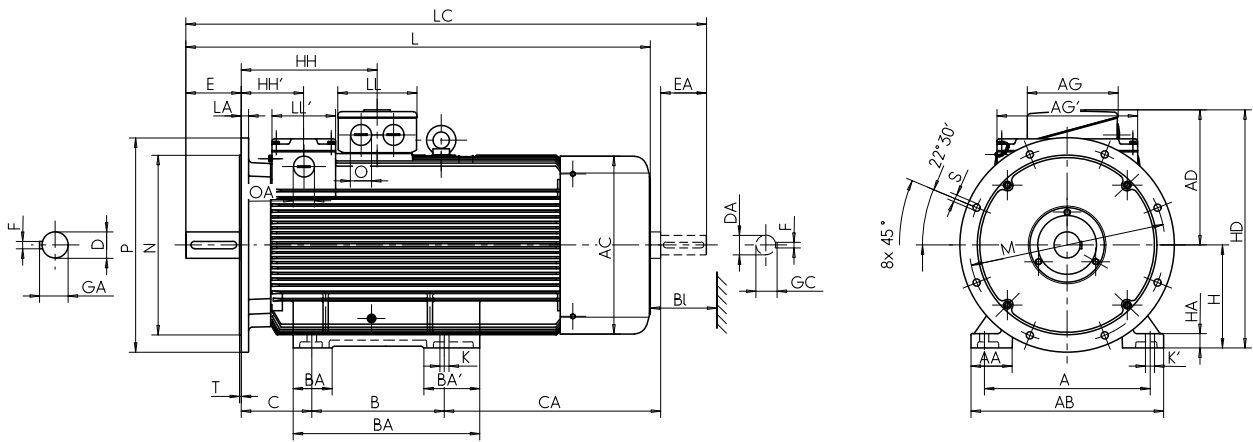

	-	-	A	AA	AB	AC	B	BA	BA'	BB	C	CA	D	DA	-	E	EA	F	FA
	B5	B35	b	n	f	g	a	e	m	m1	w1	w2	d	d1	Zentrierbohrung DIN 332-DS	l	l1	u	u1
SPR 132 M	A350	A350	216	50	256	258	178	218	55	55	89	300	38	38	M12	80	80	10	10
SPR 132 L	A350	A350	216	50	256	258	203	243	55	55	89	313	38	38	M12	80	80	10	10
SPR 160 M	A350	A400	254	55	296	313	210	257	60	60	108	339	48	42	M16	110	110	14	12
SPR 160 L	A350	A400	254	55	296	313	254	301	60	60	108	325	48	42	M16	110	110	14	12
SPR 180 M	A400	A450	279	62	328	351	241	288	65	65	121	353	55	48	M20	110	110	16	14
SPR 180 L	A400	A450	279	62	328	351	279	326	65	65	121	371	55	48	M20	110	110	16	14
SPR 200 M	A450	A450	318	70	372	390	267	322	70	70	133	431	60	55	M20	140	110	18	16
SPR 200 L	A450	A450	318	70	372	390	305	360	70	70	133	453	60	55	M20	140	110	18	16
SPR 225 M	A550	A550	356	75	413	440	311	368	75	75	149	481	65	55	M20	140	110	18	16
S10R 250 M	A550	A550	406	80	470	490	349	412	-	-	168	523	75	65	M20	140	140	20	18
S10R 250 L	A550	A550	406	80	470	490	406	469	-	-	168	546	75	65	M20	140	140	20	18
S10R 280 M	A660	A660	457	88	522	550	419	482	-	-	190	596	80	70	M20	170	140	22	20
S10R 280 L	A660	A660	457	88	522	550	457	520	-	-	190	638	80	70	M20	170	140	22	20

Drehstrommotoren mit Schleifringläufer, Grundausführung SPR/S10R 132–280

mit Oberflächenkühlung, Kühlart IC 411, Schutzart IP 54/IP 55

Bauform IM B5 [IM 3001], IM 3002; IM V1 [IM 3011], IM 3012

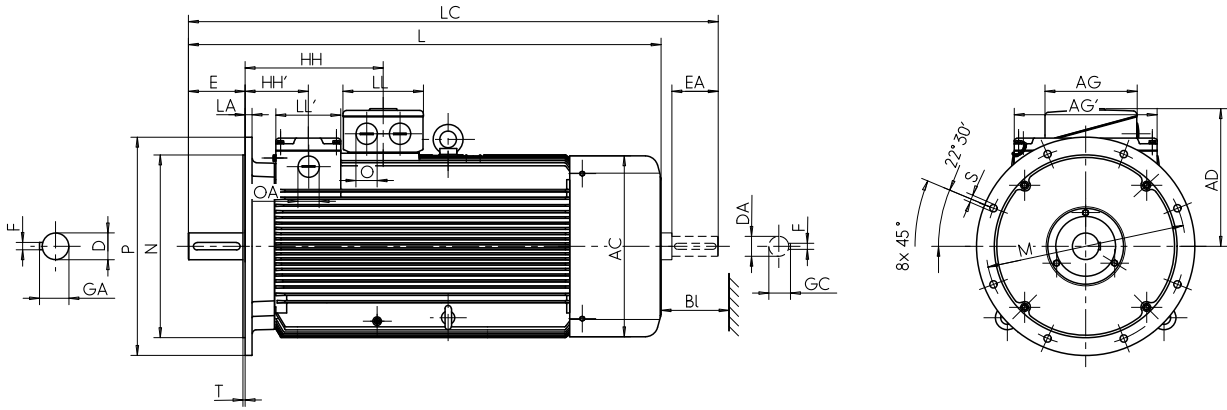

Typ	GA	GC	H	HA	HD	HD	K	K'	L	LC	LD	LD	AG	LL	O	AG'	LL'	OA	-	-	-	
	t	t1	h	c	p (B3)	p (B3 VIK KK)	s	s'	k	k1	A (IM B3)	A (IM B5)	Anschlusskasten			Schleifringraum			Bl	Lochbild	NS möglich	
													Typ	x	z	r	x'	z'	r			
SPR 132 M	41	41	132	16	331	331	12	12	643	727	242	242	25 A	156	145	M32 x 1,5	221	120	M32 x 1,5	35	4L	nein
SPR 132 L	41	41	132	16	331	331	12	12	681	765	242	242	25 A	156	145	M32 x 1,5	221	120	M32 x 1,5	35	4L	nein
SPR 160 M	51,5	45	160	18	402	402	15	15	762	877	292	292	63 A	193	167	M40 x 1,5	272	140	M40 x 1,5	35	4L	nein
SPR 160 L	51,5	45	160	18	402	402	15	15	792	907	292	292	63 A	193	167	M40 x 1,5	272	140	M40 x 1,5	35	4L	nein
SPR 180 M	59	51,5	180	20	441	441	15	15	819	935	301	301	63 A	193	167	M40 x 1,5	292	140	M40 x 1,5	35	8L	nein
SPR 180 L	59	51,5	180	20	441	441	15	15	875	991	301	301	100 A	213	207	M50 x 1,5	292	140	M50 x 1,5	35	8L	nein
SPR 200 M	64	59	200	22	500	500	19	19	957	1081	331	331	100 A	213	207	M50 x 1,5	310	145	M50 x 1,5	40	8L	nein
SPR 200 L	64	59	200	22	500	500	19	19	1017	1141	331	331	100 A	213	207	M50 x 1,5	310	145	M50 x 1,5	40	8L	ja
SPR 225 M	69	59	225	25	549	549	19	19	1069	1191	339	339	100 A	213	207	M50 x 1,5	310	145	M50 x 1,5	45	8L	ja
S10R 250 M	79,5	69	250	40	636	645	24	24	1166	1321	411	411	200 A	282	242	M63 x 1,5	382	195	M63 x 1,5	50	8L	ja
S10R 250 L	79,5	69	250	40	636	645	24	24	1246	1401	411	411	200 A	282	242	M63 x 1,5	382	195	M63 x 1,5	50	8L	ja
S10R 280 M	85	74,5	280	40	696	705	24	30	1363	1515	416	416	200 A	282	242	M63 x 1,5	382	195	M63 x 1,5	55	8L	ja
S10R 280 L	85	74,5	280	40	696	705	24	30	1443	1595	416	416	200 A	282	242	M63 x 1,5	382	195	M63 x 1,5	55	8L	ja

**Drehstrommotoren mit Schleifringläufer,
Grundausführung SPR 132–160**

mit Oberflächenkühlung, Kühlart IC 411, Schutzart IP 54/IP 55

Bauform IM B34 [IM 2101], IM 2102

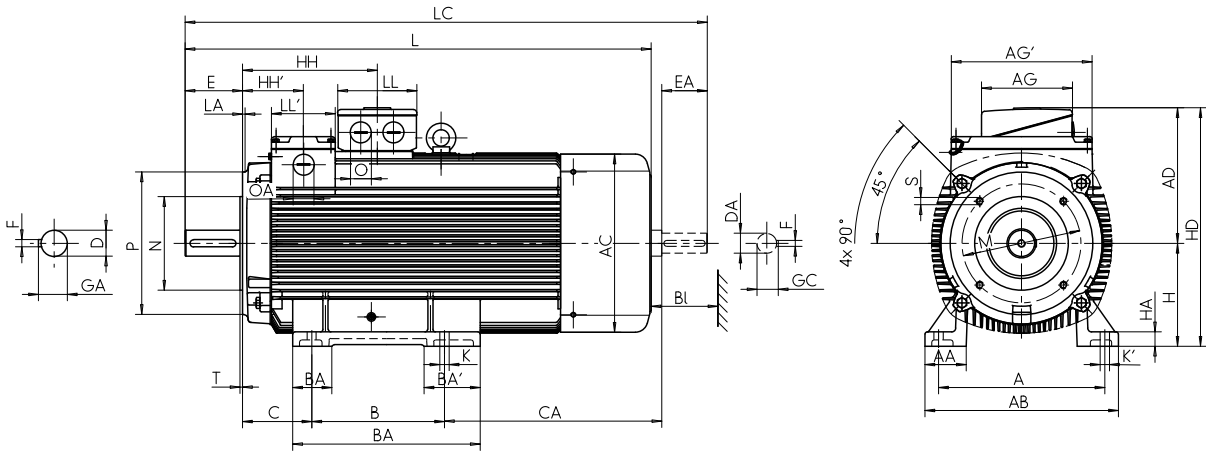

	-	-	A	AA	AB	AC	B	BB	BA	BA'	C	CA	D	DA	-	E	EA	F	FA
	B14 K, B34 K	B14 G, B34 G	b	n	f	g	a	e	m	m1	w1	w2	d	d1	Zentrierbohrung DIN 332-DS	l	l1	u	u1
SPR132 M	C200	C250	216	50	256	258	178	218	55	55	89	300	38	38	M12	80	80	10	10
SPR132 L	C200	C250	216	50	256	258	203	243	55	55	89	313	38	38	M12	80	80	10	10
SPR160 M	C250	C300	254	55	296	313	210	257	60	60	108	339	48	42	M16	110	110	14	12
SPR160 L	C250	C300	254	55	296	313	254	301	60	60	108	325	48	42	M16	110	110	14	12

Drehstrommotoren mit Schleifringläufer, Grundaufbauform SPR 132-160

mit Oberflächenkühlung, Kühlart IC 411, Schutzart IP 54/IP 55

Bauform IM B14 [IM 3601], IM 3602

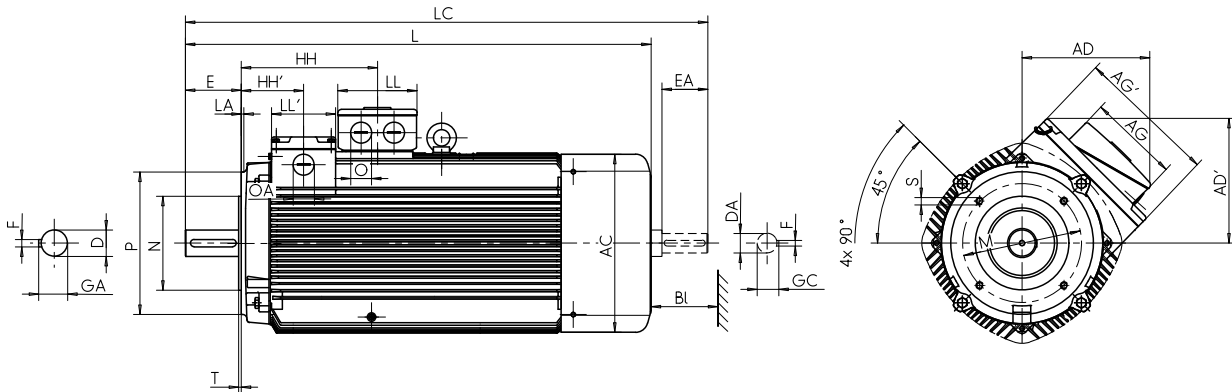

Typ	GA	GC	H	HA	HD	HD	K	K'	L	LC	LD	LD	LD	LD	Anschlusskasten				Schleifringraum			-	-
	t	t1	h	c	p (B3)	p (B3 VIK KK)	s	s'	k	k1	A (IM B3)	A (IM B5)	A (IM B14K)	A (IM B14G)	Typ	x'	z'	r	x'	z'	r	Bl	Lochbild
SPR 132 M	41	41	132	16	331	331	12	12	643	727	242	242	242	242	25 A	156	145	M32 x 1,5	221	120	M32 x 1,5	35	4L
SPR 132 L	41	41	132	16	331	331	12	12	681	765	242	242	242	242	25 A	156	145	M32 x 1,5	221	120	M32 x 1,5	35	4L
SPR 160 M	51,5	45	160	18	402	402	15	15	762	877	292	292	292	292	63 A	193	167	M40 x 1,5	272	140	M40 x 1,5	35	4L
SPR 160 L	51,5	45	160	18	402	402	15	15	792	907	292	292	292	292	63 A	193	167	M40 x 1,5	272	140	M40 x 1,5	35	4L

**Drehstrommotoren mit Schleifringläufer,
Grundausführung SPEH 132–250/S11H 250–315 M**

mit Oberflächenkühlung, Kühlart IC 411, Schutzart IP 54/IP 55

Bauform IM B3 [IM 1001], IM 1002
Zylindrisches Wellenende

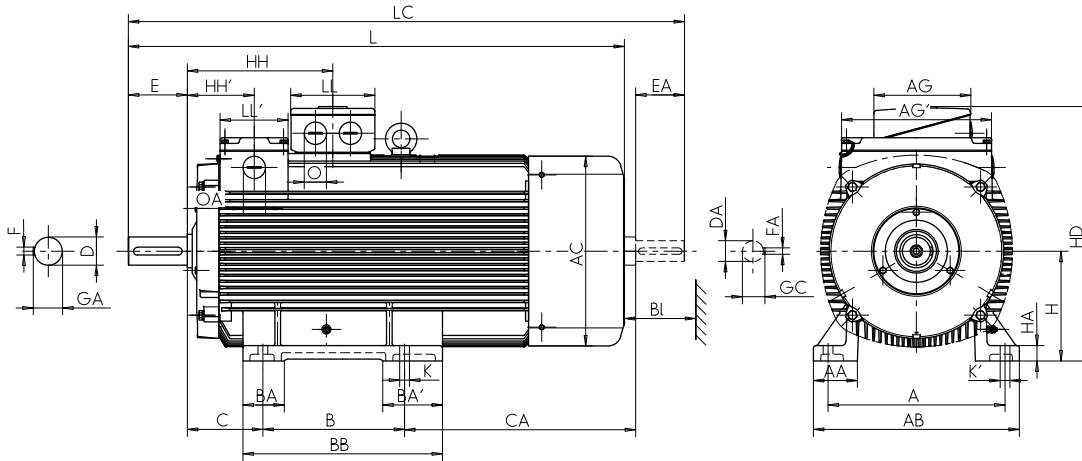

Bauform IM B3K [IM 1003], IM 1004
Kegliges Wellenende nach DIN 1448, Kegel 1:10, mit Ansatzmutter

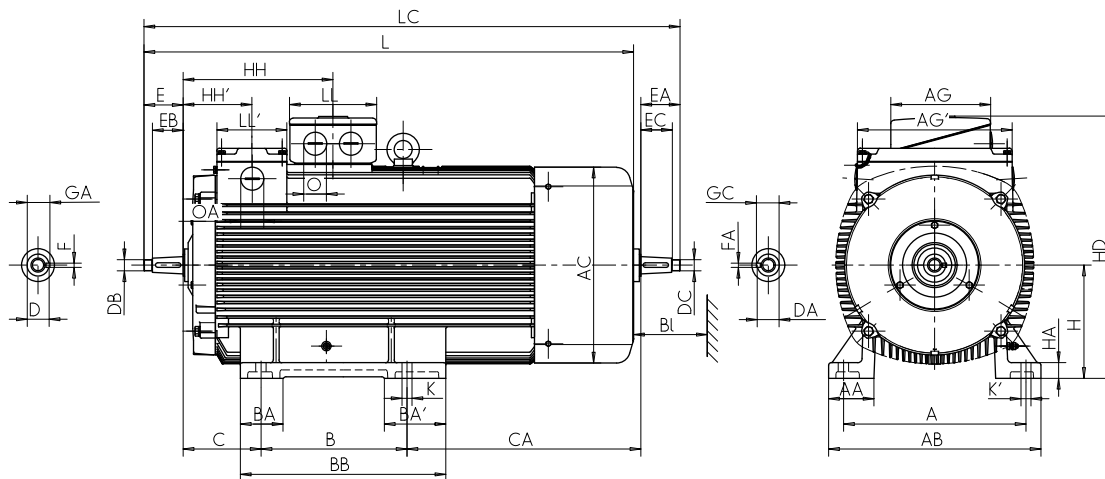

	-		A	AA	AB	AC	B	BA	BA'	BB	C	CA	D	DA	-	DB	DC	DIN	E	EA	F	FA	EB	EC	F	FA
	B5	B35	b	n	f	g	a	m	m1	e	w1	w2	d	d1	Zentrierbohrung DIN 332-DS	d2	d3	l	l1	u	u1	l2	l2	u	u1	u2
SPEH 132 M	A300	A300	216	50	256	258	178	55	55	218	89	300	38	38	M12	M24 x 2	M24 x 2	1448	80	80	10	10	58	58	6	6
SPEH 132 MX	A300	A300	216	50	256	258	178	55	55	218	89	300	38	38	M12	M24 x 2	M24 x 2	1448	80	80	10	10	58	58	6	6
SPEH 160 M	A350	A350	254	55	296	313	210	60	60	257	108	339	42	42	M16	M24 x 2	M24 x 2	1448	110	110	12	12	82	82	10	10
SPEH 160 L	A350	A350	254	55	296	313	254	60	60	301	108	305	42	42	M16	M24 x 2	M24 x 2	1448	110	110	12	12	82	82	10	10
SPEH 180 L	A350	A350	279	62	328	351	279	65	65	326	121	315	48	48	M16	M30 x 2	M30 x 2	1448	110	110	14	14	82	82	12	12
SPEH 200 L	A400	A400	318	70	372	390	305	70	70	360	133	393	55	55	M20	M36 x 3	M36 x 3	1448	110	110	16	16	82	82	14	14
SPEH 200 LX	A400	A400	318	70	372	390	305	70	70	360	133	393	55	55	M20	M36 x 3	M36 x 3	1448	110	110	16	16	82	82	14	14
SPEH 225 M	A450	A450	356	75	413	390	311	75	75	368	149	371	60	55	M20	M42 x 3	M36 x 3	1448	140	110	18	16	105	82	16	14
SPEH 225 MX	A450	A450	356	75	413	390	311	75	75	368	149	371	60	55	M20	M42 x 3	M36 x 3	1448	140	110	18	16	105	82	16	14
SPEH 250 M	A550	A550	406	84	471	440	349	84	84	412	168	426	70	60	M20	M48 x 3	M42 x 3	1448	140	140	20	18	105	105	18	16
S11H 250 MX6	A550	A550	406	84	469	490	349	84	84	412	168	524	70	60	M20	M48 x 3	M42 x 3	1448	140	140	20	18	105	105	18	16
S11H 280 S4	A550	A550	457	94	522	490	368	96	96	431	190	483	80	65	M20	M56 x 4	M42 x 3	1448	170	140	22	18	130	105	20	16
S11H 280 S8	A550	A550	457	94	522	490	368	96	138	482	190	563	80	65	M20	M56 x 4	M42 x 3	1448	170	140	22	18	130	105	20	16
S11H 280 M4	A550	A550	457	94	522	490	419	96	138	482	190	512	80	65	M20	M56 x 4	M42 x 3	1448	170	140	22	18	130	105	20	16
S11H 280 M6	A550	A550	457	94	522	490	419	96	138	482	190	512	80	65	M20	M56 x 4	M42 x 3	1448	170	140	22	18	130	105	20	16
S11H 315 S4	A660	A660	508	126	590	550	406	120	120	520	216	583	90	70	M24	M64 x 4	M48 x 3	1448	170	140	25	20	130	105	22	18
S11H 315 S6	A660	A660	508	126	590	550	406	120	172	572	216	663	90	70	M24	M64 x 4	M48 x 3	1448	170	140	25	20	130	105	22	18
S11H 315 M	A660	A660	508	126	590	550	457	120	172	572	216	612	90	70	M24	M64 x 4	M48 x 3	1448	170	140	25	20	130	105	22	18

Drehstrommotoren mit Schleifringläufer, Grundausführung SPEH 132–250/S11H 250–315 M

mit Oberflächenkühlung, Kühlart IC 411, Schutzart IP 54/IP 55

Bauform IM B35 [IM 2001], IM 2002

Zylindrisches Wellenende

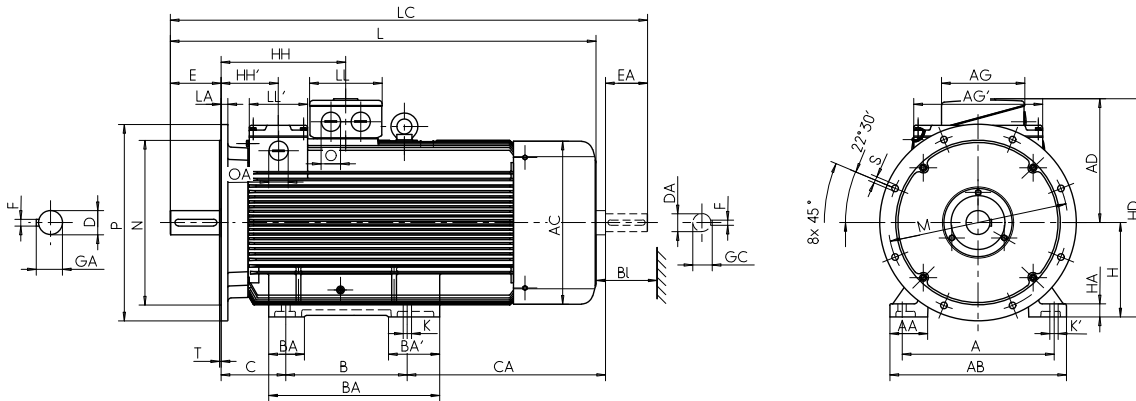

Bauform IM B35K [IM 2003], IM 2004

Kegliges Wellenende nach DIN 1448, Kegel 1:10, mit Ansatzmutter

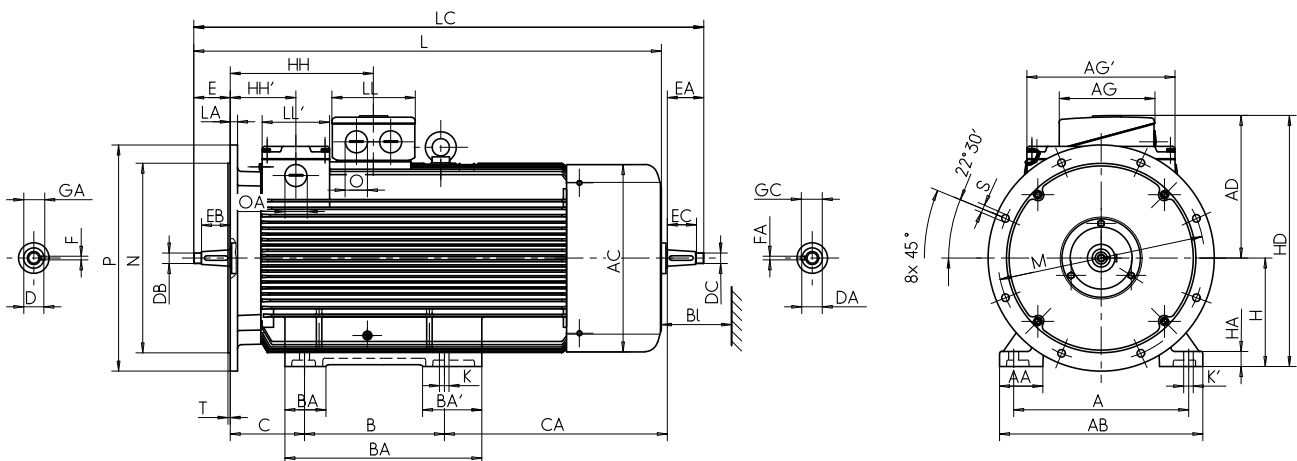

Typ	Motor dimensions													Anschlusskasten			Schleifringraum			Wellenende				
	GA	GA	GC	GC	H	HA	HD	K	K'	L	LC	LD	LD	LE	AG	LL	O	AG'	LL'	OA	-	-	-	
	t	t kegl.	t1	t1 kegl.	h	c	p	s	s'	k	k1	A (IM B3)	A (IM B5)	A1	Typ	x	z	r	x'	z'	r'	Bl	Lochbild	NS möglich
SPEH 132 M	41	39	41	39	132	16	331	12	12	643	727	242	242	-	25 A	156	145	M32 x 1,5	221	120	M32 x 1,5	35	4	nein
SPEH 132 MX	41	39	41	39	132	16	331	12	12	643	727	242	242	-	25 A	156	145	M32 x 1,5	221	120	M32 x 1,5	35	4	nein
SPEH 160 M	45	42,9	45	42,9	160	18	402	15	15	762	877	292	292	-	63 A	193	167	M40 x 1,5	272	140	M40 x 1,5	35	4	nein
SPEH 160 L	45	42,9	45	42,9	160	18	402	15	15	762	877	292	292	-	63 A	193	167	M40 x 1,5	272	140	M40 x 1,5	35	4	nein
SPEH 180 L	51,5	48,9	51,5	48,9	180	20	441	15	15	819	935	301	301	-	63 A	193	167	M40 x 1,5	292	140	M40 x 1,5	35	4	nein
SPEH 200 L	59	56,4	59	56,4	200	22	500	19	19	927	1051	331	331	-	100 A	213	207	M50 x 1,5	310	145	M50 x 1,5	40	4	nein
SPEH 200 LX	59	56,4	59	56,4	200	22	500	19	19	927	1051	331	331	-	100 A	213	207	M50 x 1,5	310	145	M50 x 1,5	40	4	nein
SPEH 225 M	64	61,4	64	61,4	225	25	525	19	19	957	1081	331	331	-	100 A	213	207	M50 x 1,5	310	145	M50 x 1,5	40	8	ja
SPEH 225 MX	64	61,4	64	61,4	225	25	525	19	19	957	1081	331	331	-	100 A	213	207	M50 x 1,5	310	145	M50 x 1,5	40	8	ja
SPEH 250 M	74,5	71,4	74,5	71,4	250	28	576	24	24	1072	1224	342	342	-	100 A	213	207	M50 x 1,5	382	195	M50 x 1,5	45	8	ja
S11H 250 MX6	74,5	71,4	74,5	71,4	250	28	636	24	24	1166	1321	411	411	-	200 A	282	242	M63 x 1,5	382	195	M63 x 1,5	50	8L	ja
S11H 280 S4	85	81,2	85	81,2	280	40	696	24	30	1201	1350	411	411	-	200 A	282	242	M63 x 1,5	382	195	M63 x 1,5	50	8L	ja
S11H 280 S8	85	81,2	85	81,2	280	40	696	24	30	1281	1430	411	411	-	200 A	282	242	M63 x 1,5	382	195	M63 x 1,5	50	8L	ja
S11H 280 M4	85	81,2	85	81,2	280	40	696	24	30	1281	1430	411	411	-	200 A	282	242	M63 x 1,5	382	195	M63 x 1,5	50	8L	ja
S11H 280 M6	85	81,2	85	81,2	280	40	696	24	30	1281	1430	411	411	-	200 A	282	242	M63 x 1,5	382	195	M63 x 1,5	50	8L	ja
S11H 315 S4	95	91,7	95	91,7	315	44	731	28	35	1348	1515	416	416	-	200 A	282	242	M63 x 1,5	430	195	M63 x 1,5	55	8L	ja
S11H 315 S6	95	91,7	95	91,7	315	44	731	28	35	1428	1595	416	416	-	200 A	282	242	M63 x 1,5	430	195	M63 x 1,5	55	8L	ja
S11H 315 M	95	91,7	95	91,7	315	44	731	28	35	1428	1595	416	416	-	200 A	282	242	M63 x 1,5	430	195	M63 x 1,5	55	8L	ja

**Drehstrommotoren mit Schleifringläufer,
Grundausführung SPEH 132–250/S11H 250–315 M**

mit Oberflächenkühlung, Kühlart IC 411, Schutzart IP 54/IP 55

Bauform IM B5 [IM 3001], IM 3002 bis Baugröße 200, IM V1 [IM 3011], IM 3012

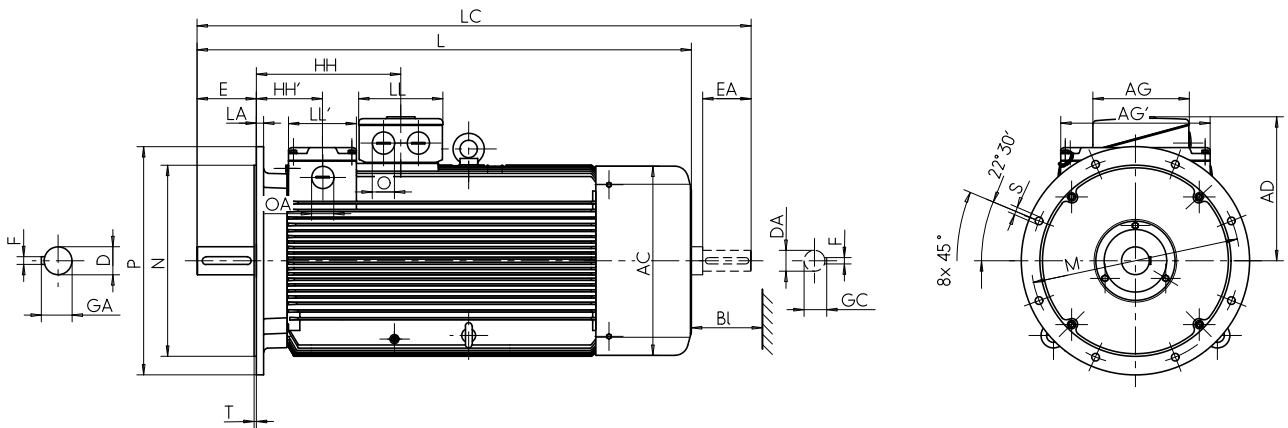

Bauform IM B5K [IM 3003], IM 3004; bis Baugröße 200, IM V1K [IM 3013], IM 3014
Kegeliges Wellenende nach DIN 1448, Kegel 1:10

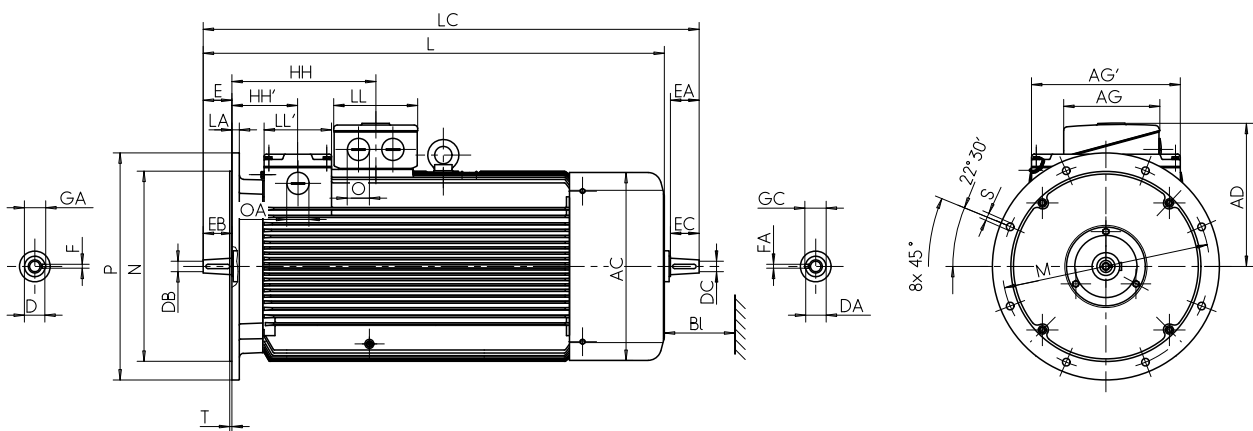

**Drehstrommotoren mit Schleifringläufer,
Grundausführung S11H 315 MX-LY**

mit Oberflächenkühlung, Kühlart IC 411, Schutzart IP 55

Bauform IM B3 [IM 1001], IM 1002

Zylindrisches Wellenende

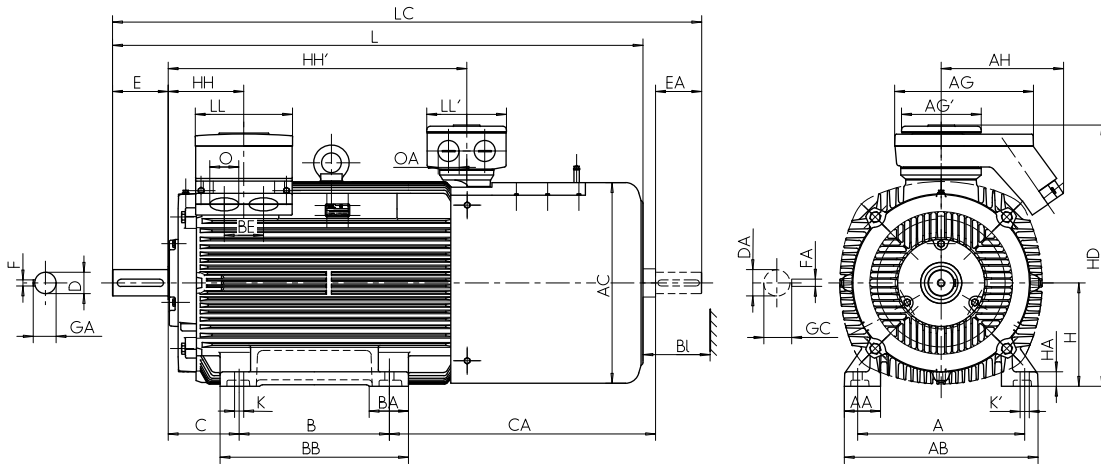

Bauform IM B3K [IM 1003], IM 1004

Kegliges Wellenende nach DIN 1448, Kegel 1:10, mit Ansatzmutter

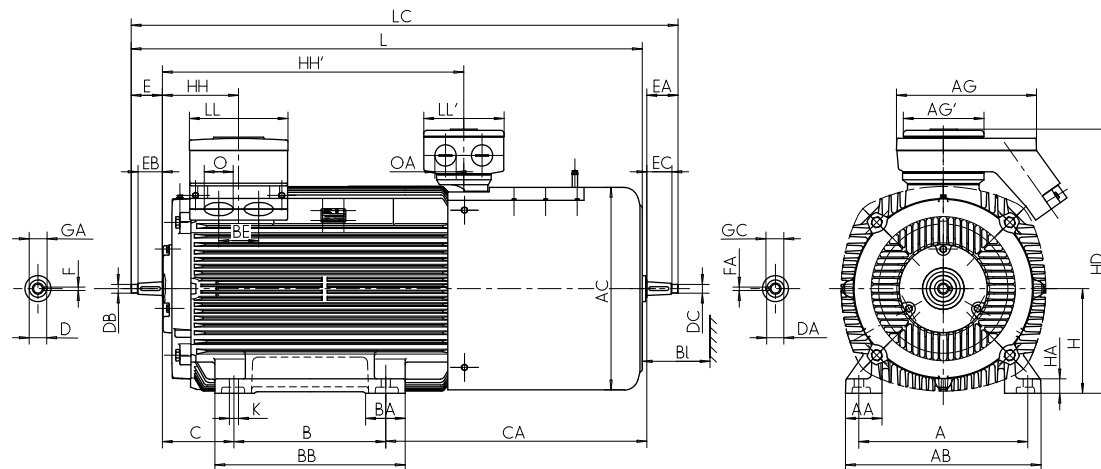

	-	-	A	AA	AB	AC	B	BA	BA'	BB	C	CA	D	DA	-	DB	DC	DIN	E	EA	F	FA	EB	EC	F	FA
	B5	B35	b	n	f	g	a	m	m1	e	w1	w2	d	d1	Zentrierbohrung DIN 332-DS	d2	d3		l	l1	u	u1	l2	l2	u kegl. Wellenende	u1 kegl. Wellenende
S11H 315 MX4	A660	A660	508	110	590	610	457	120	120	573	216	810	90	70	M24	M64 x 4	M48 x 3	1448	170	140	25	20	130	105	22	18
S11H 315 MY4	A660	A660	508	110	590	610	457	120	120	573	216	810	90	70	M24	M64 x 4	M48 x 3	1448	170	140	25	20	130	105	22	18
S11H 315 LX4	A660	A660	508	110	590	610	508	120	120	624	216	879	90	70	M24	M64 x 4	M48 x 3	1448	170	140	25	20	130	105	22	18
S11H 315 LY4	A660	A660	508	110	590	610	508	120	120	624	216	879	90	70	M24	M64 x 4	M48 x 3	1448	170	140	25	20	130	105	22	18

Drehstrommotoren mit Schleifringläufer, Grundausführung S11H 315 MX-LY

mit Oberflächenkühlung, Kühlart IC 411, Schutzart IP 55

Bauform IM B35 [IM 2001], IM 2002

Zylindrisches Wellenende

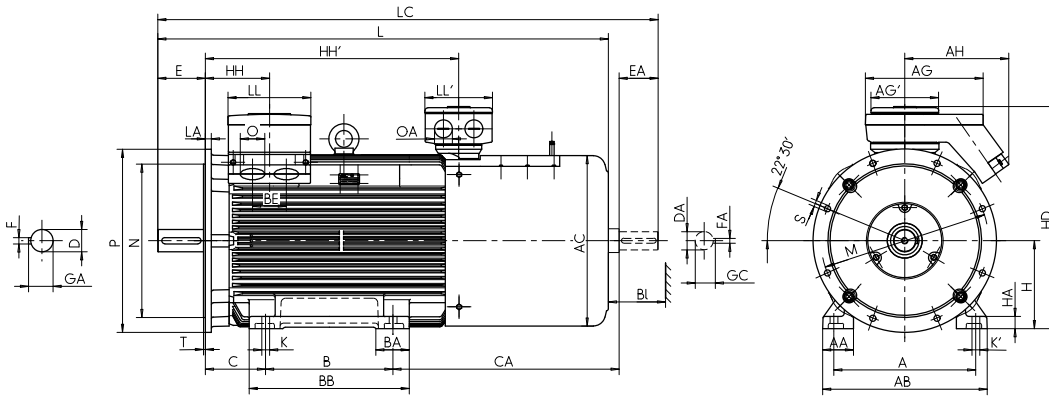

Bauform IM B35K [IM 2003], IM 2004

Kegliges Wellenende nach DIN 1448, Kegel 1:10, mit Ansatzmutter

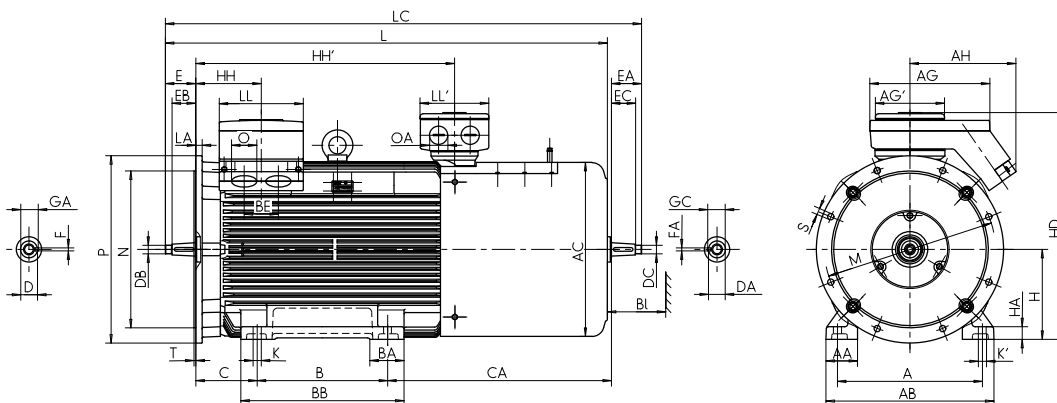

Typ	t	t kegl.	t1	t1 kegl.	h	c	p	s	s'	k	k1	A (IM B3)	A (IM B5)	A1	Anschlusskasten			Schleifringraum			- - -				
															KK Typ	x	z	r	Typ	x'	z'	r'	Bl	Lochbild	NS möglich
S11H 315 MX4	95	91,7	74,5	71,4	315	44	800	28	35	1613	1793	230	230	675	VGK400 A	422	296	Ø 95	200A	282	242	M63 x1,5	55	8L	ja
S11H 315 MY4	95	91,7	74,5	71,4	315	44	800	28	35	1613	1793	230	230	675	VGK400 A	422	296	Ø 95	200A	282	242	M63 x1,5	55	8L	ja
S11H 315 LX4	95	91,7	74,5	71,4	315	44	800	28	35	1733	1913	230	230	795	VGK400 A	422	296	Ø 95	200A	282	242	M63 x1,5	55	8L	ja
S11H 315 LY4	95	91,7	74,5	71,4	315	44	800	28	35	1733	1913	230	230	795	VGK400 A	422	296	Ø 95	200A	282	242	M63 x1,5	55	8L	ja

**Drehstrommotoren mit Schleifringläufer,
Grundausführung S11H 315 MX-LY**

mit Oberflächenkühlung, Kühlart IC 411, Schutzart IP 55

Bauform IM V1 [IM 3011]

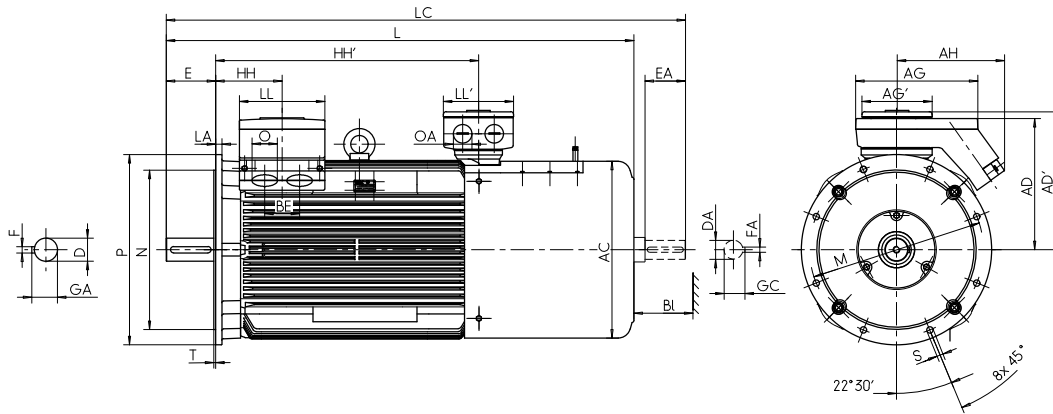

Bauform IM B5K [IM 3003], IM 3004; bis Baugröße 200, IM V1K [IM 3013], IM 3014

Kegeliges Wellenende nach DIN 1448, Kegel 1:10

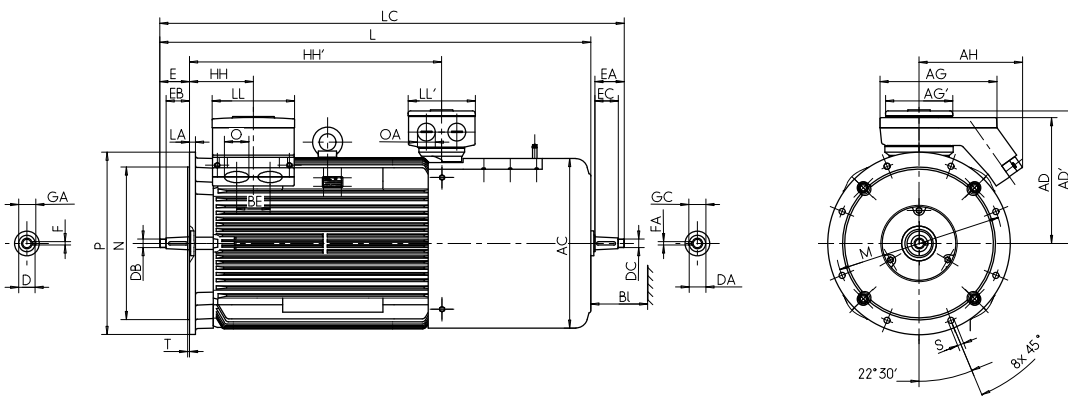

**Drehstrommotoren mit Schleifringläufer,
Grundausführung SPEH 132–160**

mit Oberflächenkühlung, Kühlart IC 411, Schutzart IP 54/IP 55

Bauform IM B34 [IM 2101], IM 2102

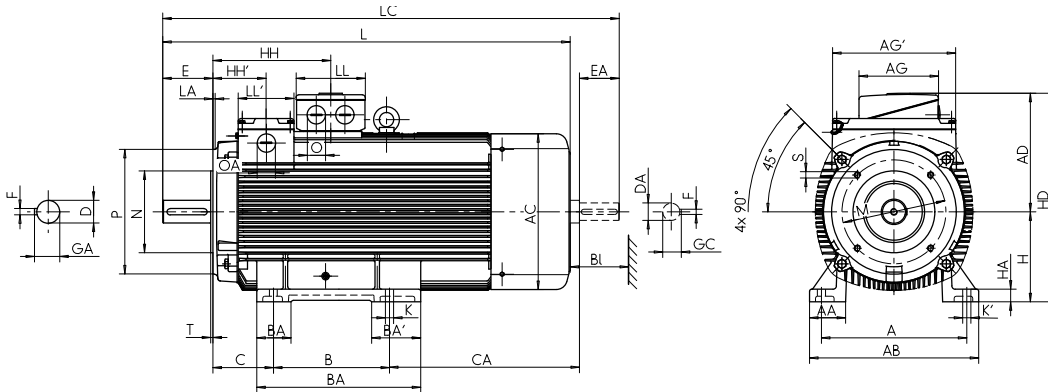

Bauform IM B34K [IM 2103], IM 2104

Kegliges Wellenende nach DIN 1448, Kegel 1:10, mit Ansatzmutter

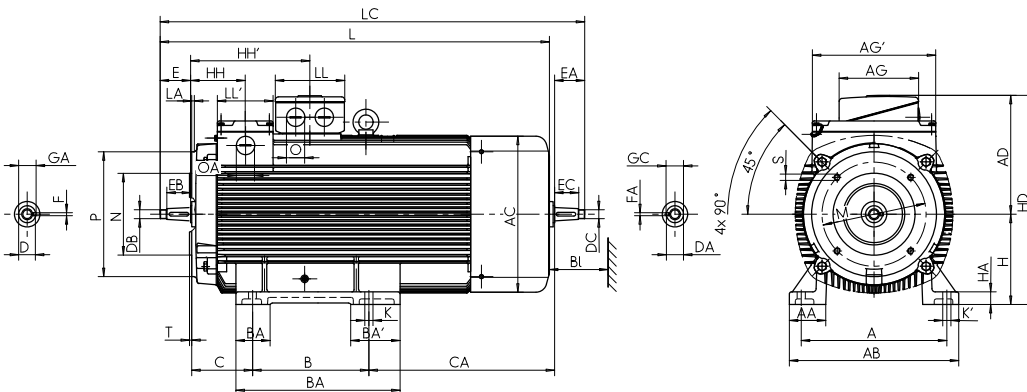

	-	-	A	AA	AB	AC	B	BA	BA'	BB	C	CA	D	DA	DB	DC	DIN	-	E	EA	F	FA	EB	EC	F	FA
	B14 K, B34 K	B14 G, B34 G	b	n	f	g	a	m	m1	e	w1	w2	d	d1	d2	d3	Zentrierbohrung DIN 332-DS	l	l1	u	u1	l2	l3	u	u1	
SPEH 132 M	C200	C250	216	50	256	258	178	55	55	218	89	300	38	38	M24 x 2	M24 x 2	1448	M12	80	80	10	10	58	58	6	6
SPEH 132 MX	C200	C250	216	50	256	258	178	55	55	218	89	300	38	38	M24 x 2	M24 x 2	1448	M12	80	80	10	10	58	58	6	6
SPEH 160 M	C250	C300	254	55	296	313	210	60	60	257	108	339	42	42	M24 x 2	M24 x 2	1448	M16	110	110	12	12	82	82	10	10
SPEH 160 L	C250	C300	254	55	296	313	254	60	60	301	108	305	42	42	M24 x 2	M24 x 2	1448	M16	110	110	12	12	82	82	10	10

Drehstrommotoren mit Schleifringläufer, Grundausführung SPEH 132–160

mit Oberflächenkühlung, Kühlart IC 411, Schutzart IP 54/IP 55

Bauform IM B14 [IM 3601], IM 3602

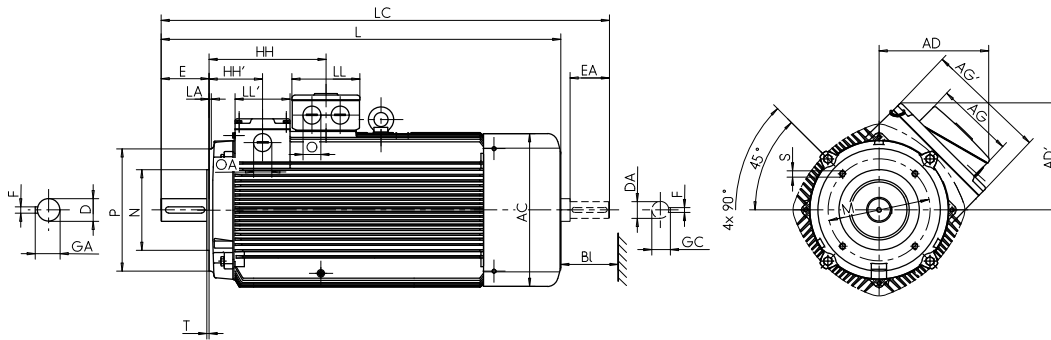

Bauform IM B14K [IM 3603], IM 3604

Kegliges Wellenende nach DIN 1448, Kegel 1:10, mit Ansatzmutter

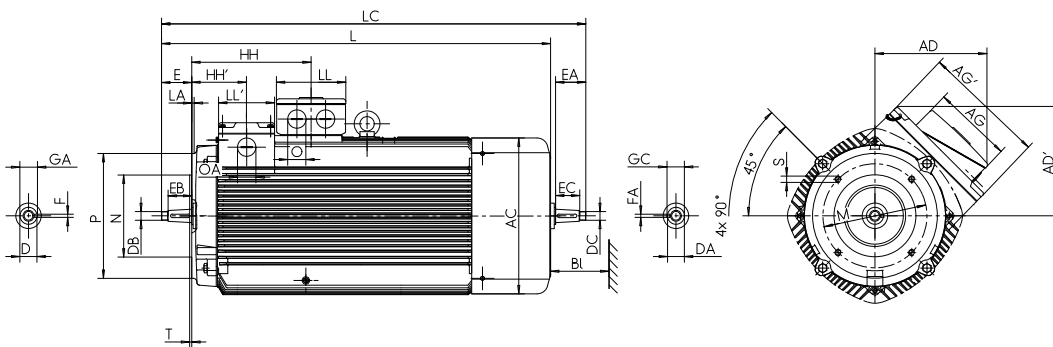

Typ	GA	GA	GC	GC	H	HA	HD	K	K'	L	LC	LD	LD	LE	AG	LL	O	AG'	LL'	OA				
	t	t kegl.	t1	t1 kegl.	h	c	p	s	s'	k	k1	A (IM B14 K)	A (IM B14 G)	A1	Anschlusskasten			Schleifringraum			Bl	Lochbild	NS möglich	
															KK Typ	x	z	r	x'	z'	r'			
SPEH 132 M	41	39	41	39	132	16	331	12	12	643	727	242	242	-	25 A	156	145	M32 x 1,5	221	120	M32 x 1,5	35	4	nein
SPEH 132 MX	41	39	41	39	132	16	331	12	12	643	727	242	242	-	25 A	156	122	M32 x 1,5	221	120	M32 x 1,5	35	4	nein
SPEH 160 M	45	42,9	45	42,9	160	18	402	15	15	762	877	292	292	-	63 A	193	167	M40 x 1,5	272	140	M40 x 1,5	35	4	nein
SPEH 160 L	45	42,9	45	42,9	160	18	402	15	15	762	877	292	292	-	63 A	193	167	M40 x 1,5	272	140	M40 x 1,5	35	4	nein

**Drehstrommotoren mit Schleifringläufer,
Grundauführung SPH/S10H 132–280**

mit Oberflächenkühlung, Kühlart IC 411, Schutzart IP 54/IP 55

Bauform IM B3 [IM 1001], IM 1002

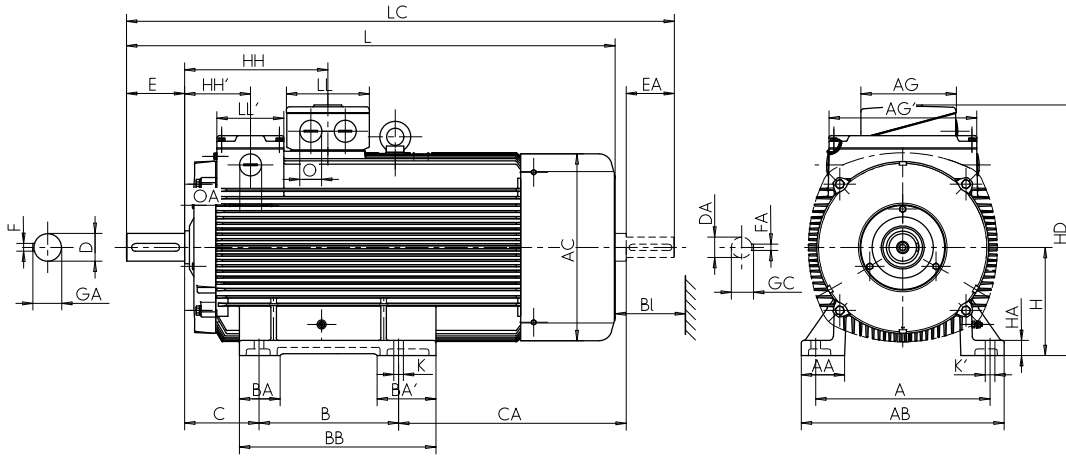

Bauform IM B3K [IM 1003], IM 1004

Kegliges Wellenende nach DIN 1448, Kegel 1:10, mit Ansatzmutter

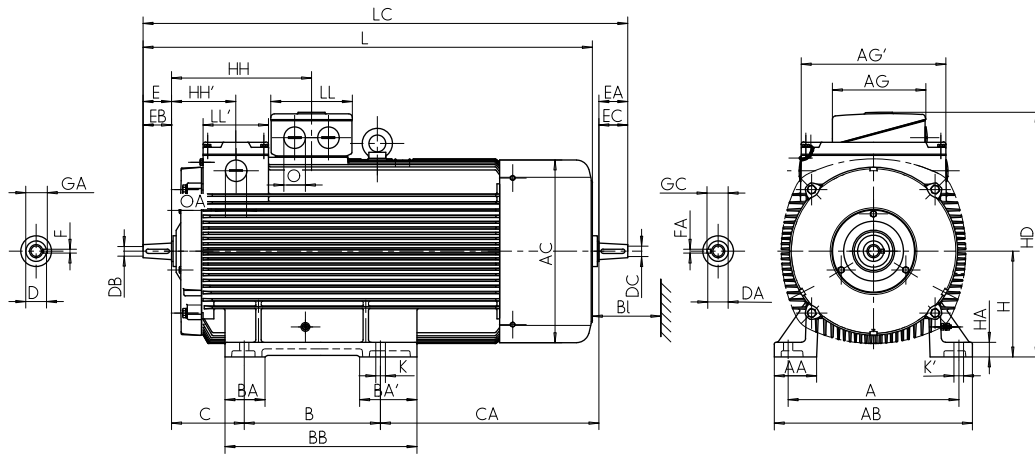

		-	-	-	-	A	AA	AB	AC	B	BA	BA'	BB	C	CA	HA	D	DA	-	E	EA	F	FA
Typ																Zentrierbohrung							
		B5	B35	B14 K, B34 K	B14 G, B34 G	b	n	f	g	a	m	m1	e	w1	w2	c	d	d1	l	l1	u	u1	
SPH 132 M	A350	A350	C200	C250	216	50	256	258	178	55	55	218	89	300	16	38	38	M12	80	80	10	10	
SPH 132 L	A350	A350	C200	C250	216	50	256	258	203	55	55	243	89	313	16	38	38	M12	80	80	10	10	
SPH 160 M	A350	A400	C250	C300	254	55	296	313	210	60	60	257	108	339	18	48	42	M16	110	110	14	12	
SPH 160 L	A350	A400	C250	C300	254	55	296	313	254	60	60	301	108	325	18	48	42	M16	110	110	14	12	
SPH 180 M	A400	A450	-	-	279	62	328	351	241	65	65	288	121	353	20	55	48	M16	110	110	16	14	
SPH 180 L	A400	A450	-	-	279	62	328	351	279	65	65	326	121	371	20	55	48	M16	110	110	16	14	
SPH 200 M	A450	A450	-	-	318	70	372	390	267	70	70	322	133	431	22	60	55	M20	140	110	18	16	
SPH 200 L	A450	A450	-	-	318	70	372	390	305	70	70	360	133	453	22	60	55	M20	140	110	18	16	
SPH 225 M	A550	A550	-	-	356	75	413	440	311	75	75	368	149	481	25	65	55	M20	140	110	18	16	
S10H 250 M	A550	A550	-	-	406	80	470	490	349	-	-	412	168	524	40	75	65	M20	140	140	20	18	
S10H 250 L	A550	A550	-	-	406	80	470	490	406	-	-	469	168	547	40	75	65	M20	140	140	20	18	
S10H 280 M	A660	A660	-	-	457	88	522	550	419	-	-	482	190	596	40	80	70	M20	170	140	22	20	
S10H 280 L	A660	A660	-	-	457	88	522	550	457	-	-	520	190	638	40	80	70	M20	170	140	22	20	

Drehstrommotoren mit Schleifringläufer, Grundauführung SPH/S10H 132–280

mit Oberflächenkühlung, Kühlart IC 411, Schutzart IP 54/IP 55

Bauform IM B35 [IM 2001], IM 2002

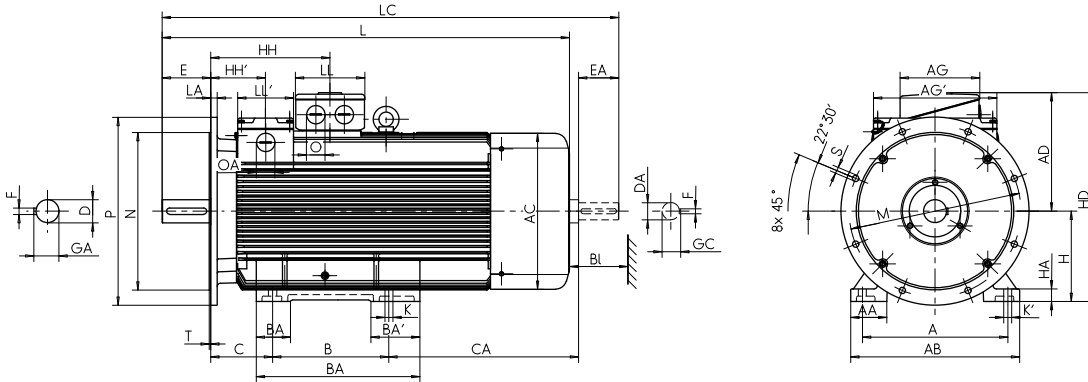

Bauform IM B35K [IM 2003], IM 2004

Kegliges Wellenende nach DIN 1449, Kegel 1:10, mit Scheibe und Befestigungsschraube

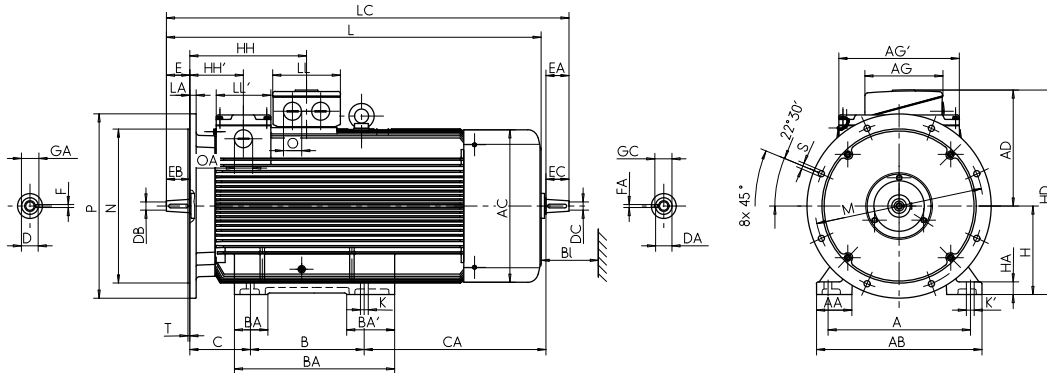

Typ	GA	GC	H	HD	HD	K	K'	L	LC	LD	LD	LD	LD	AG	LL	O	AG'	LL'	OA	-	-	-	
	t	t1	h	p (B3)	p (B3 VIK KK)	s	s'	k	k1	A (IM B3)	A (IM B5)	A (IM B14 K)	A (IM B14 G)	Anschlusskasten			Schleifringraum			Bl	Lochbild	NS möglich	
														Typ	x	z	r	x'	z'	r'			
SPH 132 M	41	41	132	331	331	12	12	643	727	242	242	242	242	25 A	156	145	M32 x 1,5	221	120	M32 x 1,5	35	4L	ja
SPH 132 L	41	41	132	331	331	12	12	681	765	242	242	242	242	25 A	156	145	M32 x 1,5	221	120	M32 x 1,5	35	4L	ja
SPH 160 M	51,5	45	160	402	402	15	15	762	877	292	292	292	292	63 A	193	167	M40 x 1,5	272	140	M40 x 1,5	35	4L	ja
SPH 160 L	51,5	45	160	402	402	15	15	792	907	292	292	292	292	63 A	193	167	M40 x 1,5	272	140	M40 x 1,5	35	4L	ja
SPH 180 M	59	51,5	180	441	441	15	15	819	935	301	301	301	301	63 A	193	167	M40 x 1,5	292	140	M40 x 1,5	35	8L	ja
SPH 180 L	59	51,5	180	441	441	15	15	875	991	301	301	301	301	100 A	213	207	M40 x 1,5	292	140	M40 x 1,5	35	8L	ja
SPH 200 M	64	59	200	500	500	19	19	957	1081	331	331	331	331	100 A	213	207	M50 x 1,5	310	145	M50 x 1,5	40	8L	ja
SPH 200 L	64	59	200	500	500	19	19	1017	1141	331	331	331	331	100 A	213	207	M50 x 1,5	310	145	M50 x 1,5	40	8L	ja
SPH 225 M	69	59	225	549	549	19	19	1069	1191	339	339	339	339	100 A	213	207	M50 x 1,5	382	195	M50 x 1,5	45	8L	ja
S10H 250 M	79,5	69	250	636	645	24	24	1166	1321	411	411	411	411	200 A	282	242	M63 x 1,5	382	195	M63 x 1,5	50	8L	ja
S10H 250 L	79,5	69	250	636	645	24	24	1246	1400	411	411	411	411	200 A	282	242	M63 x 1,5	382	195	M63 x 1,5	50	8L	ja
S10H 280 M	85	74,5	280	696	705	24	30	1363	1515	416	416	416	416	200 A	282	242	M63 x 1,5	430	195	M63 x 1,5	55	8L	ja
S10H 280 L	85	74,5	280	696	705	24	30	1443	1595	416	416	416	416	200 A	282	242	M63 x 1,5	430	195	M63 x 1,5	55	8L	ja

**Drehstrommotoren mit Schleifringläufer,
Grundaussführung SPH/S10H 132–280**

mit Oberflächenkühlung, Kühlart IC 411, Schutzart IP 54/IP 55

Bauform IM B5 [IM 3001]

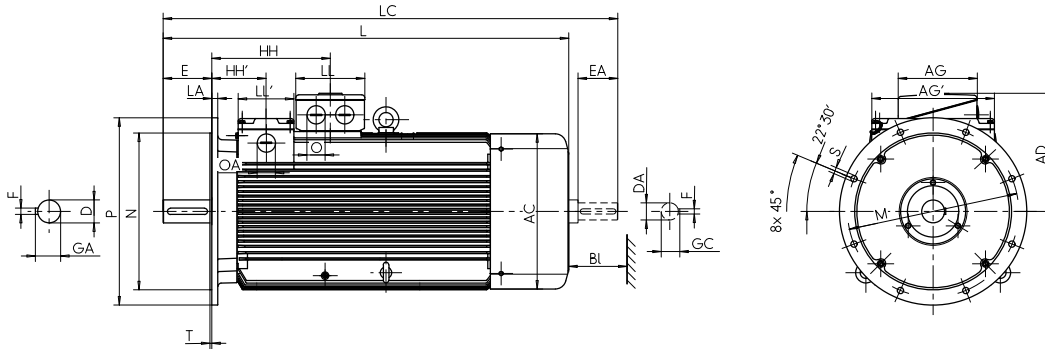

Bauform IM B5K [IM 3003], IM 3004

Kegliges Wellenende nach DIN 1449, Kegel 1:10, mit Scheibe und Befestigungsschraube

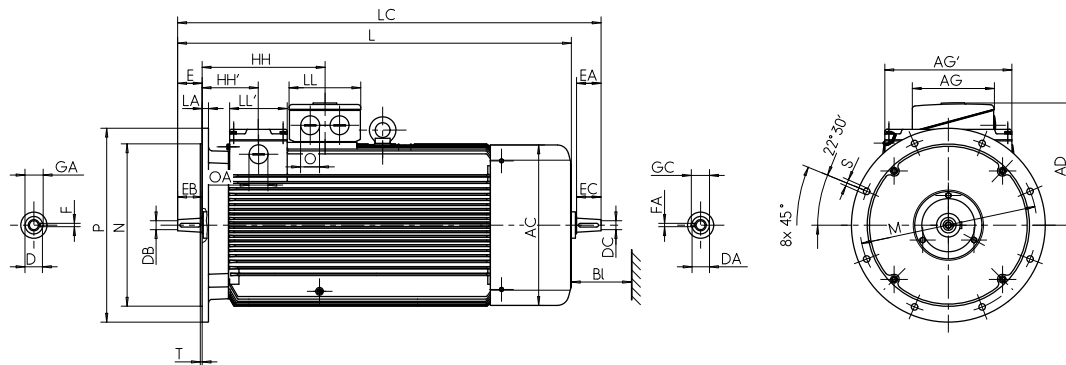

**Drehstrommotoren mit Schleifringläufer,
Grundausführung SPH 132–160**

mit Oberflächenkühlung, Kühlart IC 411, Schutzart IP 54/IP 55

Bauform IM B34 [IM 2101], IM 2102

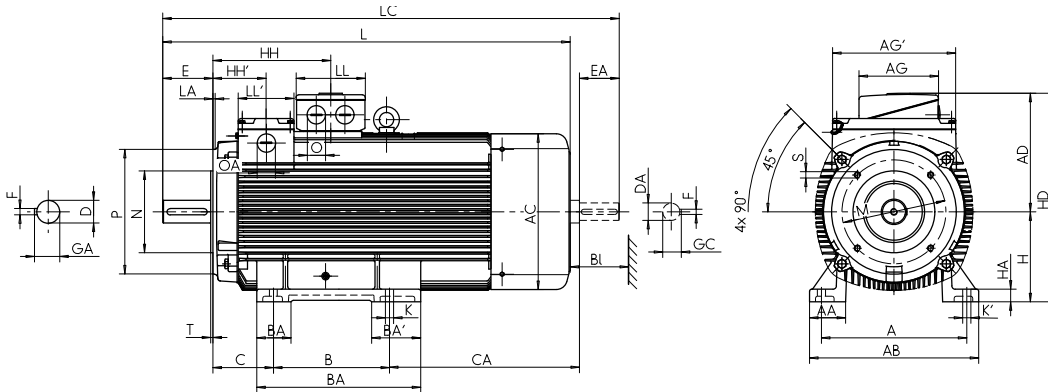

Bauform IM B34K [IM 2103], IM 2104

Kegliges Wellenende nach DIN 1449, Kege1 1:10, mit Scheibe und Befestigungsschraube

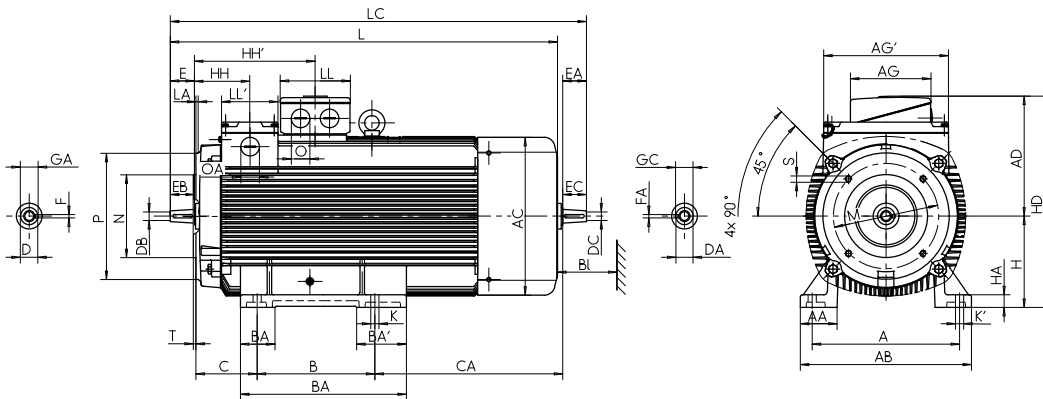

		A	AA	AB	AC	B	BA	BA'	BB	C	CA	HA	D	DA	-	E	EA	F	FA
B14 K, B34 K	B14 G, B34 G	b	n	f	g	a	m	m1	e	w1	w2	c	d	d1	Zentrierbohrung	l	l1	u	u1
SPH 132 M	C200 C250	216	50	256	258	178	55	55	218	89	300	16	38	38	M12	80	80	10	10
SPH 132 L	C200 C250	216	50	256	258	203	55	55	243	89	313	16	38	38	M12	80	80	10	10
SPH 160 M	C250 C300	254	55	296	313	210	60	60	257	108	339	18	48	42	M16	110	110	14	12
SPH 160 L	C250 C300	254	55	296	313	254	60	60	301	108	325	18	48	42	M16	110	110	14	12

Drehstrommotoren mit Schleifringläufer, Grundausführung SPH 132–160

mit Oberflächenkühlung, Kühlart IC 411, Schutzart IP 54/IP 55

Bauform IM B14 [IM 3601], IM 3602

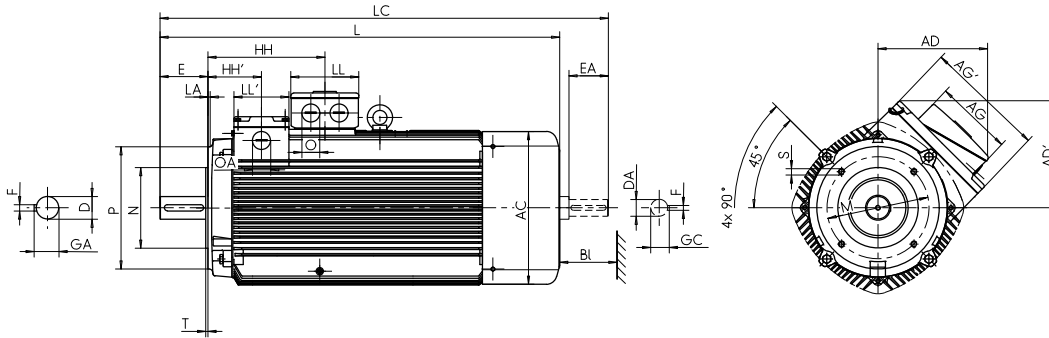

Bauform IM B14K [IM 3603], IM 3604

Kegliges Wellenende nach DIN 1449, Kegel 1:10, mit Scheibe und Befestigungsschraube

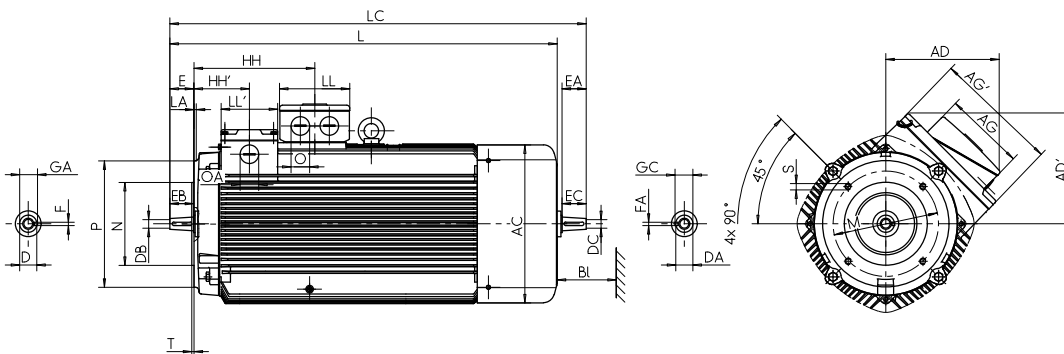

Typ	GA	GC	H	HD	HD	K	K'	L	LC	LD	LD	AG	LL	O	AG'	LL'	OA	-			
	t	t1	h	p (B3)	p (B3 VIK Kk)	s	s'	k	k1	A (IM B14 K)	A (IM B14 G)	Anschlusskasten			Schleifringraum			Bl	Lochbild	NS möglich	
												Typ	x	z	r	x'	z'	r'			
SPH 132 M	41	41	132	331	331	12	12	643	727	242	242	25 A	156	145	M32 x 1,5	221	120	M32 x 1,5	35	4L	ja
SPH 132 L	41	41	132	331	331	12	12	681	765	242	242	25 A	156	145	M32 x 1,5	221	120	M32 x 1,5	35	4L	ja
SPH 160 M	51,5	45	160	402	402	15	15	762	877	292	292	63 A	193	167	M40 x 1,5	272	140	M40 x 1,5	35	4L	ja
SPH 160 L	51,5	45	160	402	402	15	15	792	907	292	292	63 A	193	167	M40 x 1,5	272	140	M40 x 1,5	35	4L	ja

VEM Holding GmbH

Pirnaer Landstraße 176
01257 Dresden
Deutschland

VEM Vertrieb

Fachbereich Niederspannung

Tel. +49 3943 68-3127
Fax +49 3943 68-2440
E-Mail: niederspannung@vem-group.com

Fachbereich Hochspannung

Tel. +49 351 208-3237
Fax +49 351 208-1108
E-Mail: hochspannung@vem-group.com

Fachbereich Antriebssysteme

Tel. +49 351 208-1180
Fax +49 351 208-1185
E-Mail: antriebssysteme@vem-group.com

VEM Kundendienst

Tel. +49 351 208-3237
Fax +49 351 208-1108
E-Mail: service@vem-group.com



Ausführliche Informationen
finden Sie auf unserer Homepage.

www.vem-group.com